



**YAMAHA**

# **XS650 E**

## **ASSEMBLY MANUAL**

**FOR XS650E MODELS AFTER ENGINE SERIAL NO. 2F0-006501**

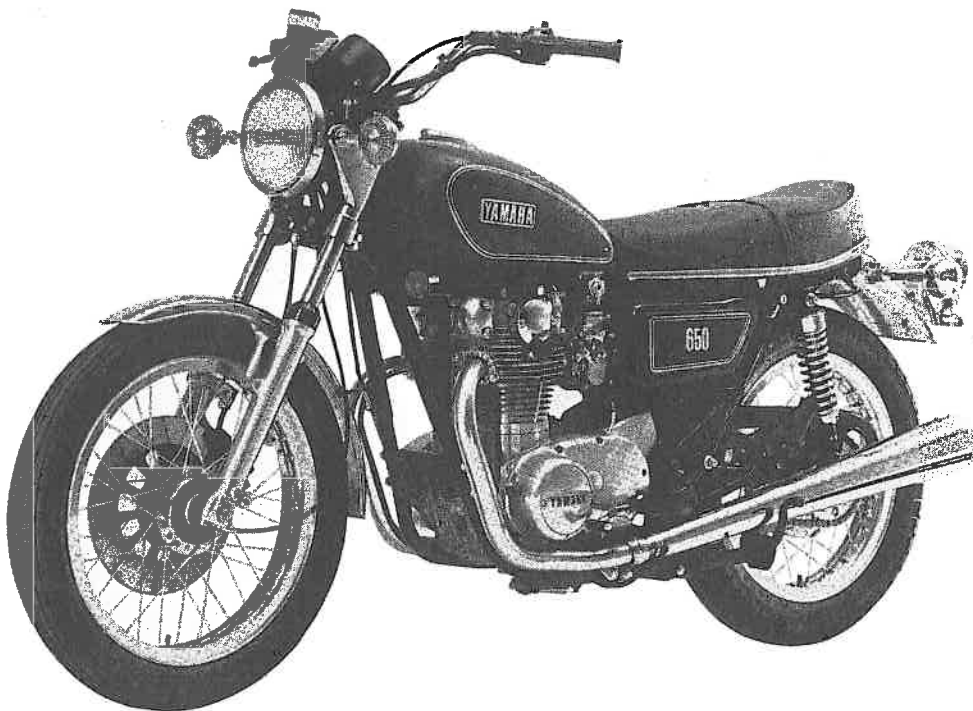

**90894-07802**

Particularly important information is distinguished in this manual by the following notations:

- NOTE:** A NOTE provides key information to make procedures easier or clearer.
- CAUTION:** A CAUTION indicates special procedures that must be followed to avoid damage to the machine.
- WARNING:** A WARNING indicates special procedures that must be followed to avoid injury to a machine operator or person inspecting or repairing the machine.

**YAMAHA XS650E  
ASSEMBLY MANUAL  
2nd EDITION, DECEMBER 1977  
OVERSEAS SERVICE DEPARTMENT  
YAMAHA MOTOR CO., LTD.  
LIT-11666-01-03**

## **FOREWORD**

The Assembly Manual contains the information required to unpack and assemble Yamaha motorcycles correctly prior to delivery to the customer. Proper motorcycle set-up assembly and pre-delivery service demands a basic knowledge of motorcycle service procedures, familiarity with Yamaha products, and correct tools. This assembly manual should be used with the Dealer Set-up and Pre-delivery Check List, Service Manual, and Parts List for this model.

Proper set-up assembly and pre-delivery service is necessary for the following reasons:

To assure the customer of the long life and performance he expects from his new Yamaha motorcycle.

To minimize service problems during the break-in period.

To conform with federal new vehicle regulations.

## NOTICE

To service specifications given in this manual are based on the model as manufactured. Modifications and significant changes in specifications and/or procedures will be forwarded to all Authorized Yamaha Dealers.

The procedures below are described in the order that the mechanic should follow. Special care should be taken to ensure that the procedures are carried out correctly and completely. Failure to do so can result in poor performance, excessive emissions, and possible harm to the machine and/or rider.

THE DEALER SET-UP AND PRE-DELIVERY CHECK LIST has been designed to be used with this Assembly Manual. As each procedure is satisfactorily completed, the mechanic should mark the appropriate space on the sheet. After it has been signed by the assembling mechanic, the servicing mechanic, and the customer, a copy of the Check List should be given to the customer and another copy retained in the DEALERSHIP files. If the Service Manager test rides the machine before delivery, he should also sign the Check List.

**CONCERNING CRATE DAMAGE:**

**Follow the instructions in the Dealer Warranty Handbook, Procedure Section.**

# UNPACKING

## Note on transportation

Use care not to butt the machine packed in the crate against a hard object or give it a heavy shock during transportation or in the service shop.

# PREPARATION

To assemble the machine correctly, the following service tools, supplies, and working space are required:

## Supplies

Oils, greases, shop rags, electrical contact cleaner.

## Workshop

The workshop where the machine is assembled should be clean and large. The floor should be level.

## Procedure for unpacking

To remove the machine and parts packed in the cardboard crate, cut the vinyl bands around the box using a cutter or scissors. Next, remove the exterior carton by lifting it straight up.

Remove the seat, right-side muffler and front wheel.

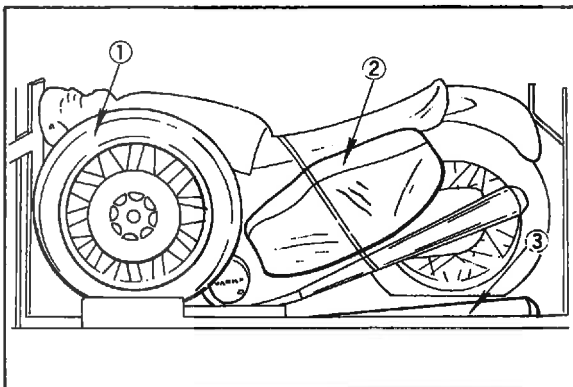

- 1. Front wheel
- 2. Seat
- 3. Right side muffler

Remove the front fender held between the rear tire and the rear fender. Next, remove the battery.

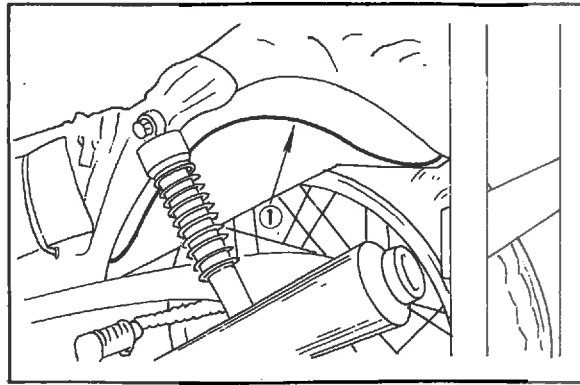

1. Front fender

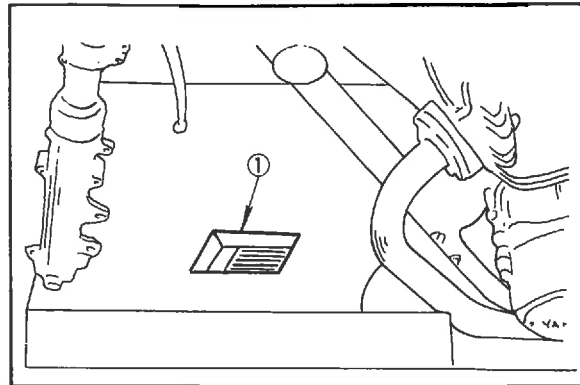

1. Battery

Remove the nails from each corner of the crate, and remove the struts.

Lift up the machine, and remove the rear wheel section from the styrofoam base. Then take out the machine.

To install the front fender and front wheel, place a proper-size wooden box or a wooden block under the engine to keep the front of the machine raised off the floor. Take care so that the machine does not fall over.

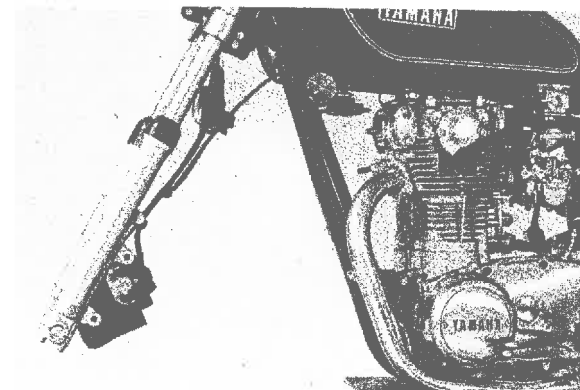

# PARTS CHECK LIST

Before starting the assembly, check for damaged or missing parts (list below).

Also check the machine for damage, scratches and other defects.

The following parts are contained in the foam

tray and the vinyl bag in the package. Check the quantity of parts against the list. Also check for damage.



**Parts List: Foam tray**



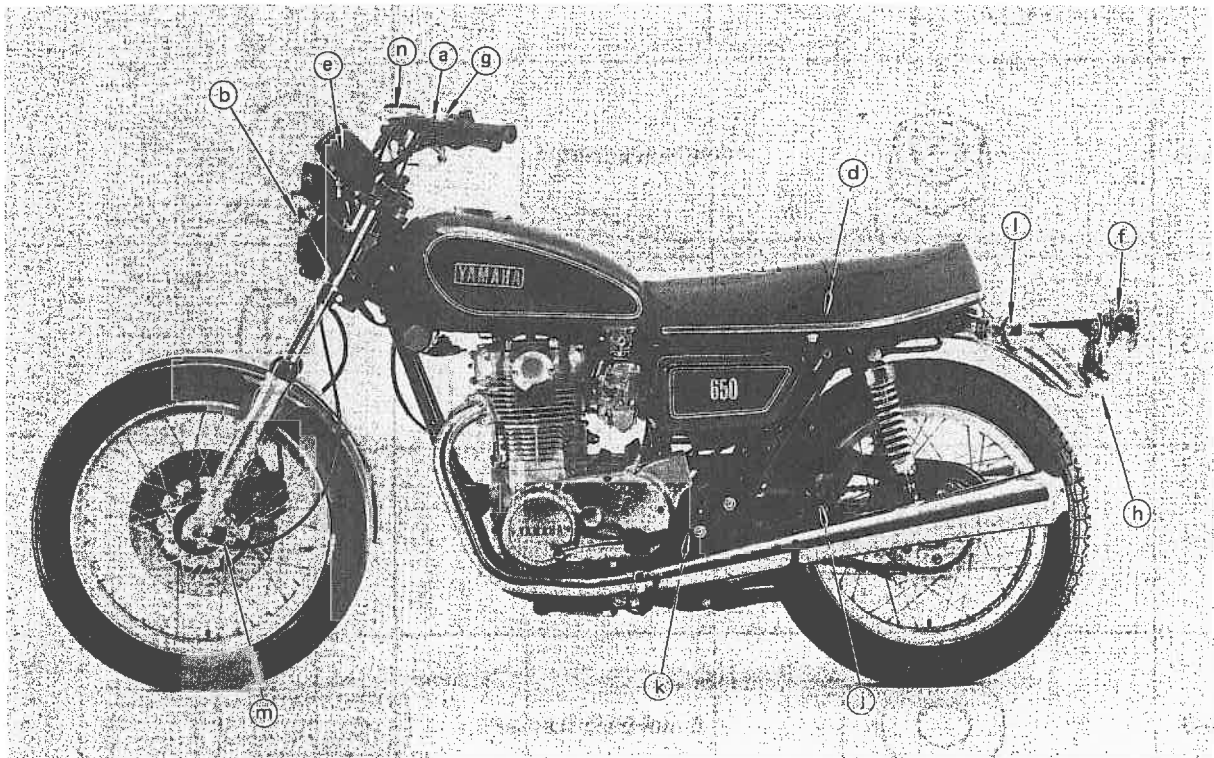

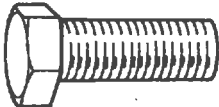

No.	Parts Name	Q'ty
a	Handlebar assembly	1
b	Front flasher light	2
c	Vinyl bag	2
d	Service tool	1
e	Meter assembly	1
f	Taillight assembly	1
g	Rear view mirror	1



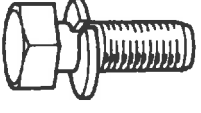
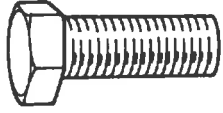

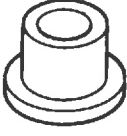



No.	Parts Name	Q'ty
h	Number support	1
i	Owner's Manual	1
j	Rear footrest (Right)	1
k	Front footrest (Right)	1
l	Rear flasher light	1
m	Speedometer clutch assembly	1
n	Master cylinder	1

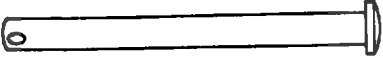



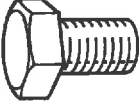

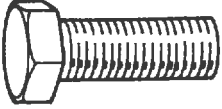

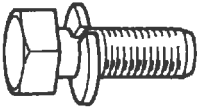

**Parts List: Vinyl bag**



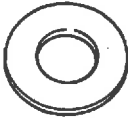



No.	Illustration	Part name	Q'ty	Remarks
a-1		10 mm bolt	2	For muffler installation
a-2		10 mm spring washer	2	



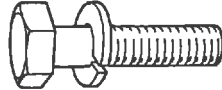



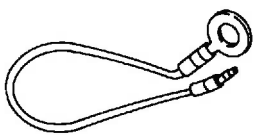
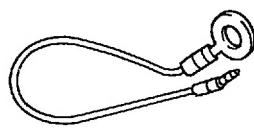

No.	Illustration	Part name	Q'ty	Remarks
a-3		Muffler band	1	For muffler installation
a-4		10 mm bolt with spring washer	2	
b-1		6 mm bolt	2	For meter assembly installation
b-2		6 mm nut	2	
b-3		Damper	4	
b-4		6 mm spring washer	2	
b-5		6 mm plate washer	2	
b-6		Collar	2	
b-7		6 mm plate washer	2	



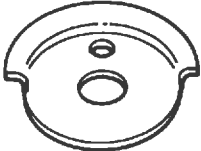

No.	Illustration	Part name	Q'ty	Remarks
c-1		Clevis pin	2	For seat installation
c-2		Clip	1	
c-3		Stopper	1	
c-4		6 mm spring washer	1	
c-5		6 mm bolt	1	
c-6		Seat bracket	1	
c-7		6 mm bolt	2	
d-1		Master cylinder bracket	1	For master cylinder installation
d-2		6 mm bolt with washer	2	

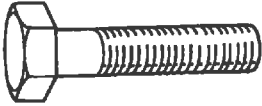
No.	Illustration	Part name	Q'ty	Remarks
d-3		Blind plug	1	For meter assembly installation
e-1		Handlebar upper holder	2	For handlebar installation
e-2		Hexagon socket head bolt	4	
e-3		Bolt cap	4	
f-1		Rubber damper	2	For front footrest installation
f-2		10 mm plate washer	2	
f-3		6 mm spring washer	2	
f-4		Cap nut	2	
g-1		Plate washer	1	For rear footrest installation

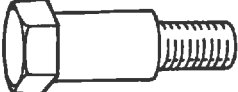

No.	Illustration	Part name	Q'ty	Remarks
g-2		Self locking nut	2	For rear footrest installation
h		8 mm bolt with spring washer	4	For front fender installation
i		Wire holder	1	For speedometer cable
j		Brake hose holder	1	For brake hose
k		Cotter pin	1	For front wheel axle installation
l		Negative lead wire	2	For front flasher light installation
m-1		Negative lead wire	2	For rear flasher light installation
m-2		Flasher light damper	2	
m-3		Flasher collar	2	

No.	Illustration	Part name	Q'ty	Remarks
m-4		8 mm spring washer	2	For rear flasher light installation
m-5		8 mm nut	2	
m-6		Special washer	2	
n-1		Grommet	1	For taillight installation
n-2		Collar	1	
n-3		6 mm plain washer	1	
n-4		6 mm bolt	1	
n-5		6 mm nut	3	
n-6		6 mm spring washer	3	

No.	Illustration	Part name	Q'ty	Remarks
n-7		Shoulder bolt	2	For taillight installation
n-8		8 mm plain washer	2	
n-9		Damper	1	
o		Fitting screw	1	For headlight unit

### TORQUE SPECIFICATIONS

The list below covers those stud/bolt sizes with standard I.S.O. pitch threads. Torque specifications for components with thread pitches other than standard are given within the applicable chapter. Torque specifications call for dry, clean threads. Components such as the cylinder or cylinder head should be at room temperature prior to torquing. A cylinder head or any other item with several fasteners should be torqued down in a cross-wise pattern in successive stages until torque specification is reached. The method

is similar to installing an automobile wheel and will avoid warping the component.

A	B	General Torque Specifications	
		m-kg	ft-lb
10 mm	6 mm	1.0	7.2
12 mm	8 mm	2.0	15
14 mm	10 mm	4.0	29
17 mm	12 mm	4.5	33
19 mm	14 mm	5.0	36
22 mm	18 mm	6.5	47
24 mm	18 mm	7.0	50
27 mm	20 mm	8.0	58

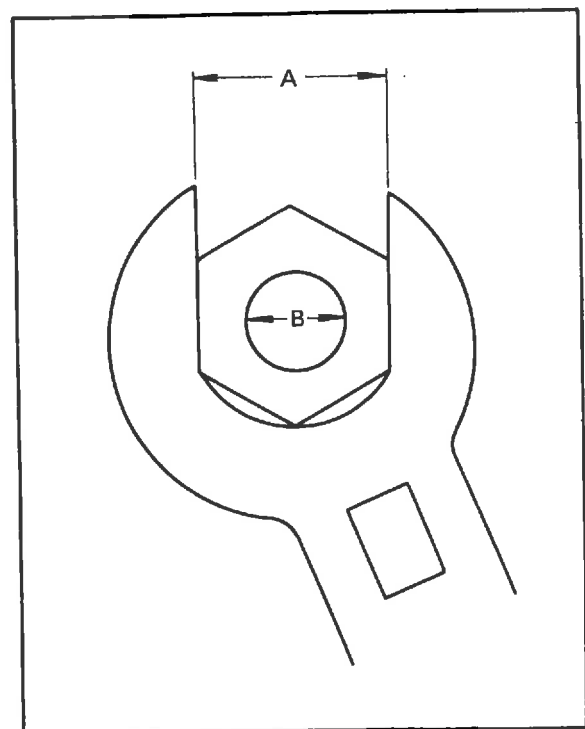

A. Distance across flats  
B. Outside thread diameter

## TORQUE SPECIFICATION CHART

PART TO BE TIGHTENED	TIGHTENING TORQUE
Spark plug	2.0 m-kg (14.5 ft-lb)
Drain plug	4.4 m-kg (31.8 ft-lb)
Exhaust pipe	1.5 m-kg (10.9 ft-lb)
Change pedal	1.0 m-kg ( 7.2 ft-lb)
Front wheel axle	8.5 m-kg (61.5 ft-lb)
Outer tube and axle holder	1.5 m-kg (10.9 ft-lb)
Handle crown and inner tube	1.0 m-kg ( 7.2 ft-lb)
Handle crown and steering shaft 8 mm	1.0 m-kg ( 7.2 ft-lb)
Handle crown and steering shaft 14 mm	5.5 m-kg (39.8 ft-lb)
Handle crown and handlebar holder	2.5 m-kg (18.1 ft-lb)
Under bracket and inner tube	1.5 m-kg (10.9 ft-lb)
Engine mounting bolt 10 mm	5.0 m-kg (36.2 ft-lb)
Engine mounting bolt 8 mm	2.0 m-kg (14.5 ft-lb)
Engine mounting bolt 10 mm (rear upper)	4.5 m-kg (32.6 ft-lb)
Front flasher and headlight	1.0 m-kg ( 7.2 ft-lb)
Master cylinder and brake hose	2.5 m-kg (18.1 ft-lb)
Brake disc and hub	2.0 m-kg (14.5 ft-lb)
Caliper and support bracket	2.0 m-kg (14.5 ft-lb)
Caliper and pad	0.3 m-kg ( 2.2 ft-lb)
Caliper and bleed screw	0.6 m-kg ( 4.3 ft-lb)
Support bracket and front fork	3.5 m-kg (25.3 ft-lb)
Master cylinder and cylinder bracket	0.6 m-kg ( 4.3 ft-lb)
Pivot shaft	6.5 m-kg (47.0 ft-lb)
Rear wheel axle	15.0 m-kg (108.5 ft-lb)
Tension bar and brake plate	2.0 m-kg (14.5 ft-lb)
Tension bar and rear arm	2.0 m-kg (14.5 ft-lb)
Rear shock absorber	3.0 m-kg (21.7 ft-lb)
Rear arm and rear arm end	1.0 m-kg ( 7.2 ft-lb)
Sprocket wheel	3.0 m-kg (21.7 ft-lb)
Handle crown and meter bracket	2.5 m-kg (18.1 ft-lb)
Front fender	1.0 m-kg ( 7.2 ft-lb)
Neutral switch and engine	1.5 m-kg (10.9 ft-lb)



# YAMAHA MOTORCYCLE

## DEALER SET-UP AND PRE-DELIVERY CHECK LIST

I hereby certify that prior to delivery to the retail purchaser, assembly and pre-delivery service was performed on the motorcycle listed below in accordance with the following check list and in compliance with established procedures prescribed by Yamaha.

MODEL \_\_\_\_\_ FRAME NO. \_\_\_\_\_ ENGINE NO. \_\_\_\_\_

Assemble according to the assembly manual and any technical bulletin information that applies to this particular model. Pay special attention to the following items.

### SET-UP ASSEMBLY

- FRONT FORK PINCH BOLTS - Torque to specification
- FRONT WHEEL AND AXLE - Torque axle and axle holder to specifications
- FRONT AXLE COTTER PIN - Install
- HANDLEBAR HOLDER (spring tension type) - Position die marks on holder to front, torque to specifications
- HANDLEBAR HOLDER (standard) - tighten bolts evenly, in a crisscross pattern until proper torque is attained
- WIRING CONNECTORS - Check for color code and proper connection
- FRONT BRAKE CABLE (drum brake) - Install
- MASTER CYLINDER (disc brake) - Install
- INSTRUMENTS - Install instruments and route the cables as shown on cable routing diagrams
- TAILLIGHT - Install on applicable models
- BRAKE PEDAL - Install per assembly manual
- ALL NUTS AND BOLTS - Check tightness and proper torque
- CONTROLS - Check for proper operation
- KEYS - Check all locks for proper operation

SET-UP BY \_\_\_\_\_ DATE \_\_\_\_\_

### PRE-DELIVERY SERVICE

- ALL NUTS AND BOLTS - Check for torque and tightness, especially:  Engine mounting bolts and/or nuts.  Setting head,  Rear swingarm pivot shaft  Axles
- HYDRAULIC DISC BRAKES (front & rear) - Check master cylinder fluid level, bleed systems, check and adjust free play, and check operation.
- TWIN FRONT DISC BRAKE - Check clearances between caliper brackets and disc, reposition if necessary
- TIRES - Adj. pressure: front \_\_\_\_\_ rear \_\_\_\_\_
- SPOKES - Check tightness
- FUEL FILTER SCREEN AND FUEL LINE - Clean and check for connection tightness
- CARBURETOR - Drain stale fuel from lines and float bowls
- CARBURETOR - Tighten caps and mounting bolts
- CARBURETOR - Adjust starter lever freeplay (if applicable)
- CARBURETOR - Adjust throttle cable freeplay
- MECHANICAL BRAKES - Check and adjust freeplay, check operation
- CLUTCH - Check and adjust freeplay
- COMPRESSION RELEASE CABLE (if applicable) - Check and adjust freeplay
- ENGINE/TRANSMISSION OIL - Drain and refill, qty \_\_\_\_\_ type \_\_\_\_\_
- SHAFT DRIVE GEAR OIL LEVELS - Check oil levels, add as necessary
- BATTERY - Charge until specific gravity reaches 1.26~1.28 according to Service Manual procedure. Install and route breather tube checking for restrictions
- ELECTRICAL COMPONENTS - Check for proper operation of: Headlamp (Hi, Lo), Turn signals, (Stoplight front, rear), Taillight, Indicator lights, Instrument lights, Horn
- DRIVE CHAIN - Lubricate, if necessary, and adjust, align rear wheel
- FOAM AIR FILTER - Service

### 2-STROKE ONLY:

- AUTOLUBE TANK - Fill tank, oil type \_\_\_\_\_ Check breather tube routing
- AUTOLUBE PUMP - Bleed air from pump and all lines
- AUTOLUBE PUMP - Adjust cable and check minimum stroke
- AUTOLUBE OIL DELIVERY - Check oil delivery to cylinders and for leaks

### EXHAUST EMISSIONS CONTROL

The following items are related to emissions control. Check and adjust if necessary in accordance with the Yamaha published service manual and technical bulletins for this particular model.

- CAM CHAIN TENSIONER (if applicable) - Adjust
- VALVES - Clearance: Intake mm, Exhaust mm
- SPARK PLUG GAP - Check: mm
- IGNITION POINTS (if applicable) - Check gap mm
- IGNITION TIMING - Check:  Idle,  Advance
- CARBURETOR - Check synchronization (if applicable)
- IDLE SPEED - Check: rpm

- TEST RIDE - Check performance, handling and operation, adjust mirrors
- OPTIONAL SERVICE MANAGER TEST RIDE \_\_\_\_\_

Service Manager Signature \_\_\_\_\_

### CUSTOMER CHECK LIST

- RECEIVED TOOL KIT (if applicable)
- RECEIVED OWNERS WARRANTY GUIDE
- RECEIVED OWNERS MANUAL
- RECEIVED SERVICE INSTRUCTIONS

I have performed the pre-delivery adjustments as specified in the assembly manual, service specifications and any technical bulletins applying to this model.

\_\_\_\_\_  
CUSTOMER DATE \_\_\_\_\_

\_\_\_\_\_  
PRE DELIVERED BY DATE \_\_\_\_\_

DEALERSHIP NAME \_\_\_\_\_

DEALER NO. \_\_\_\_\_

ADDRESS \_\_\_\_\_

CITY/STATE/ZIP CODE \_\_\_\_\_

WHITE - DEALER FILE COPY

CANARY - CUSTOMER COPY

## SET-UP PROCEDURES

Insert the front fender between the front forks, and secure the front fender using bolts and spring washers (h).

### NOTE:

Do not forget to fit brake hose holder (j) as in the photo before securing the bolts.

Tightening torque:  
1.0 m-kg (7.2 ft-lb)

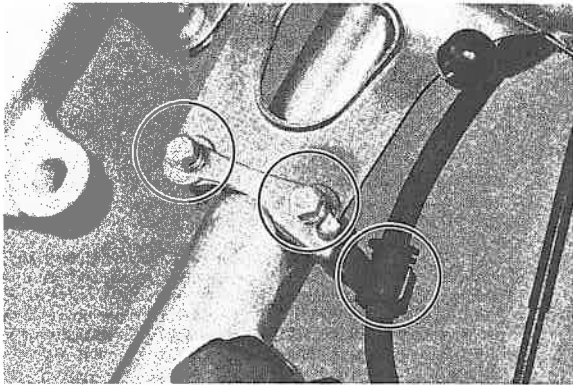

Install the wire holder (i) on the front fender.

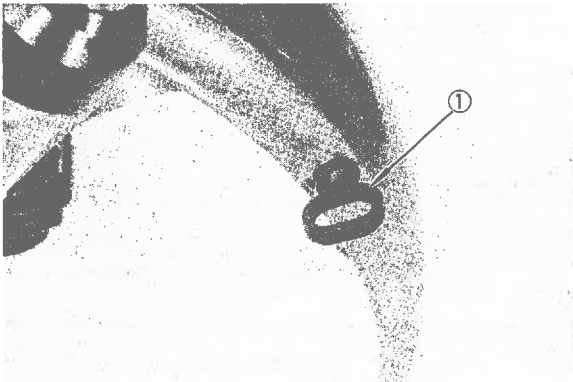

1. Wire holder

Install the speedometer clutch assembly on the left side of the front wheel.

1. Apply a light coat of lithium base grease to the oil seal lip on the front wheel side.
2. Apply a thin coat of lithium base grease to the meter drive gear and driven gear on the meter clutch side.
3. Make sure the two projections inside the wheel hub are meshed with the two slots in the speedometer clutch assembly.

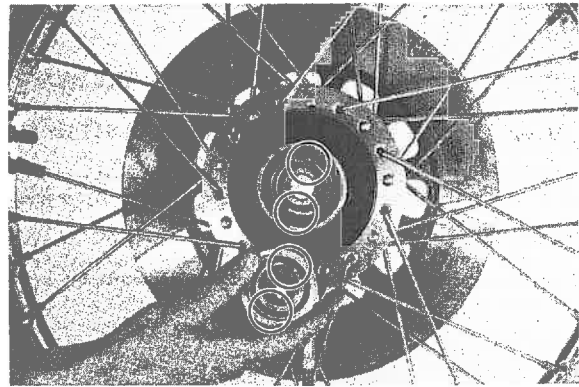

Install the front wheel on the front forks.

1. Remove the front wheel axle nut and plain washer, and loosen the two nuts securing the axle holder. Then remove the wheel axle.
2. Install the wheel axle collar in the wheel hub on the right side of the front wheel.

### NOTE:

To avoid damaging the oil seal lip, apply a light coat of lithium base grease to the axle collar. If the collar is dirty, clean with a rag.

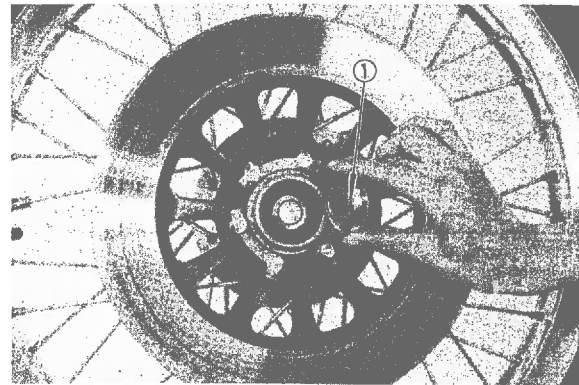

1. Wheel axle collar

3. Make sure there is an enough gap between the disc pads, and check if the brake disc can be inserted between the disc pads by inserting from the front side of the machine. Then place the front wheel between the front fork legs.
4. Insert the wheel axle from the left side of the wheel hub, mount the plain washer and install the axle nut. Before tightening the nut, position the meter clutch assembly correctly as shown, and tighten the nut to specification.

Axle Nut Torque:  
8.5 m-kg (61.5 ft-lb)

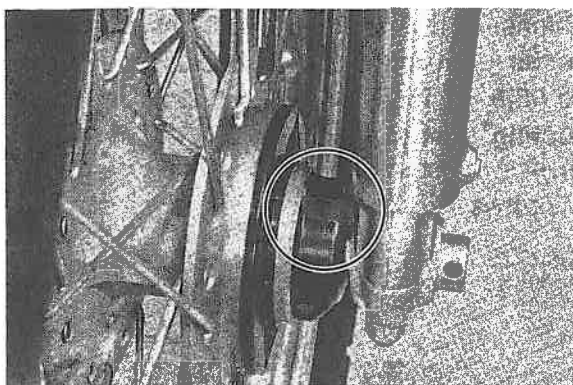

5. Lock the nut with the cotter pin (k). The pin should be inserted downward, and the pin ends should be bent.
6. Install the axle holder as shown. First tighten the nut on the front end of the axle holder, and tighten the nut on the rear end.

**Tightening Torque:**  
1.5 m-kg (10.9 ft-lb)

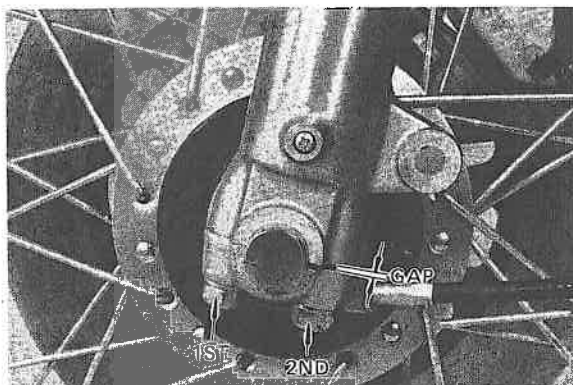

### Handlebar installation

1. Remove the anchor screw from the left part of the headlight shell. The screw (o) for the right part contains in the vinyl bag. Insert a slotted-head screwdriver between the shell and the lens assembly mounting ring on the bottom of the headlight shell, and pry out the lens assembly.

**NOTE:** Care should be taken not to scratch the headlight shell with the slotted-head screwdriver. Also be careful not to lose any screw.



1. Anchor screw (Left side)

2. Install the handlebar using the two handlebar upper holders (e-1), four hexagon socket head bolts (e-2) and four bolt caps (e-3).

**CAUTION:** First tighten the bolts on the front side of the handlebar holder and then tighten the bolts on the rear side.

**Tightening Torque:**  
2.5 m-kg (18.1 ft-lb)

3. Insert the lead wire coming from the handlebar switch into the grommet attached to the headlight body.

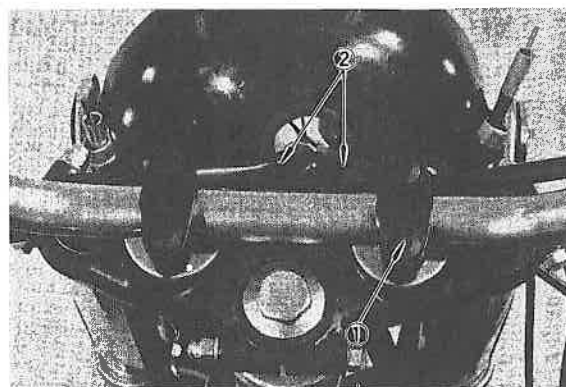

1. Bolt cap 2. Lead wire

### Meter bracket installation

1. Using the bolts (b-1), plate washers (b-7), dampers (b-3), collars (b-6), plate washers (b-5), spring washers (b-4) and nuts (b-2) contained in the vinyl bag as in the photo, install the meter bracket assembly on the handle crown.

**NOTE:** Before securing the meter bracket, all wires should be threaded through the headlight

body grommet. Take care not to kink wires by pressure.

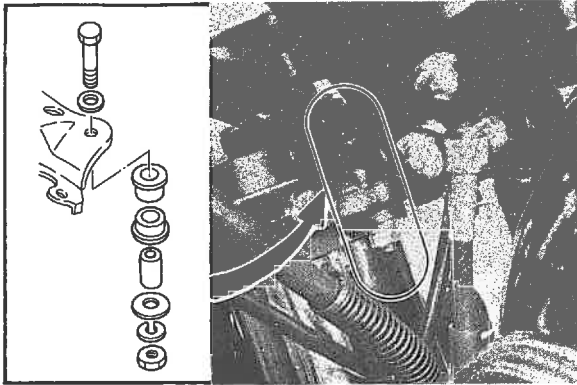

Connect the tachometer cable to the tachometer and connect the speedometer cable to the speedometer. For detailed cable routing, refer to illustration.

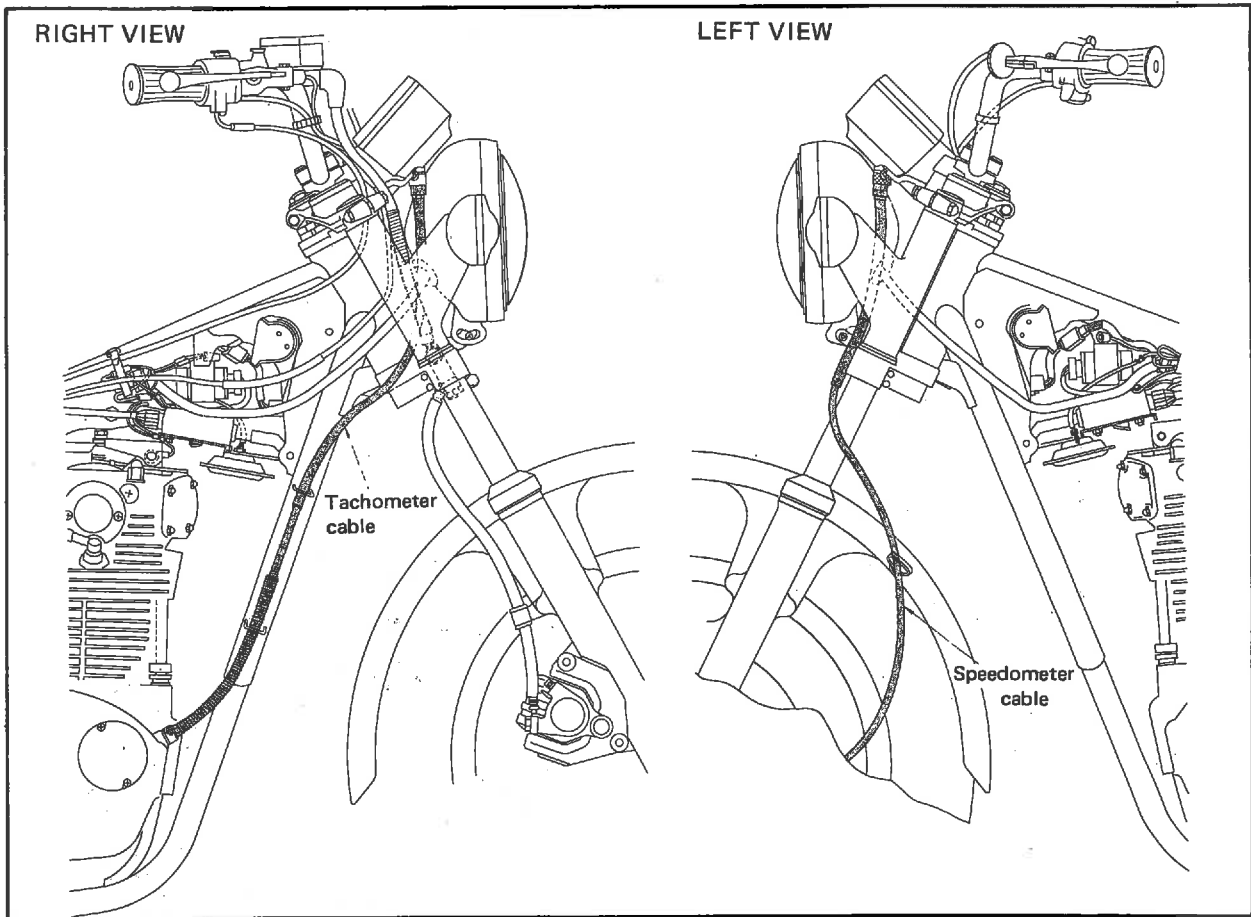

### Throttle cable installation

1. Remove the two screws securing the right handlebar switch assembly, and separate the switch assembly into the upper and lower halves.

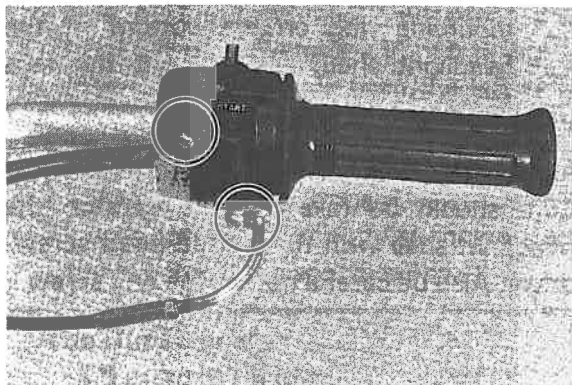



2. Thread the throttle cable through the hole in lower handlebar switch. Hook the throttle cable end onto its seat in the throttle guide housing. Then, grease the throttle cable and housing. And fit the collar before the handlebar switch.

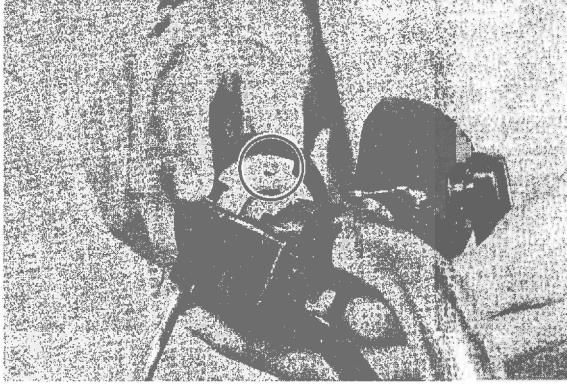

3. Put together the upper and lower handlebar switch halves with bolts and check the accelerator grip for smooth action.

Using the bolts with spring washers (d-2) and master cylinder bracket (d-1) contained in the vinyl bag, install the front brake master cylinder assembly on the handlebars.

**NOTE:**

The front brake master cylinder bracket should be installed with the "UP" mark on it on top.

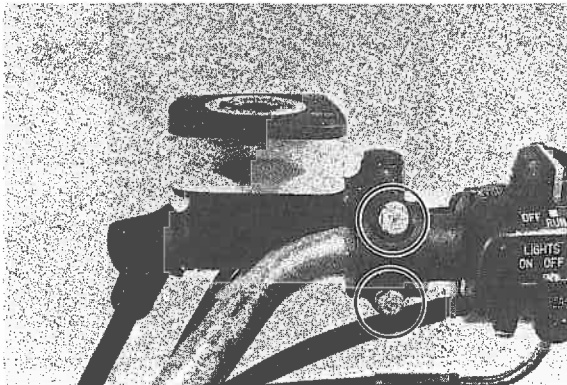

**Clutch cable installation**

1. Fully loosen the lower adjuster lock nut, and screw in the adjuster until tight. Next, align the slit in the adjuster and adjuster lock nut with the slit in the lever holder.

2. Insert the cable end into the lever hole, and hook the outer cable end onto the adjuster lock nut, then squeeze the lever. Next, while pulling the outer cable in the direction opposite to the lever; release the lever quickly. Release the lever quickly. While releasing it, seat the outer cable into the adjuster.

**CAUTION:**

Proper cable and wire routing is essential to ensure safe vehicle operation. For details of the cable routing, refer to the cable routing diagram.

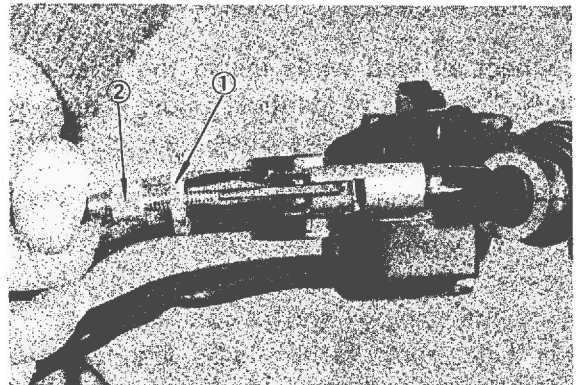

1. Lock nut 2. Adjuster

Install the rear view mirror assembly on the left side of the handlebars. Adjust for proper rear view. Next, install the blind plug on the right handlebar switch.

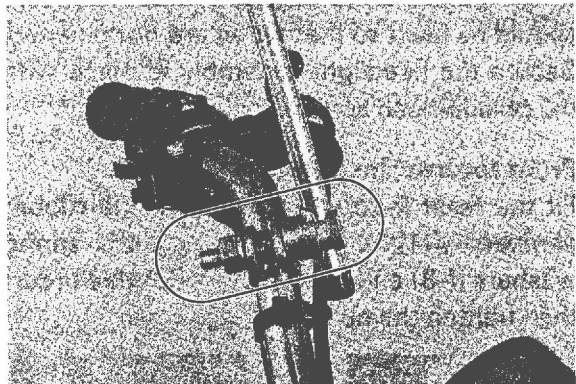

**Front flasher light installation**

1. Remove the bolts, spring washers and nuts securing the headlight body assembly to the light stay.
2. Install both right and left flasher light assemblies to the headlight body through the stays, and install the negative lead wires (I), spring washers and nuts as illustrated. Then tighten the nuts.

**NOTE:** \_\_\_\_\_

The two removed bolts are "temporary", and therefore, they are not used for the final assembly.

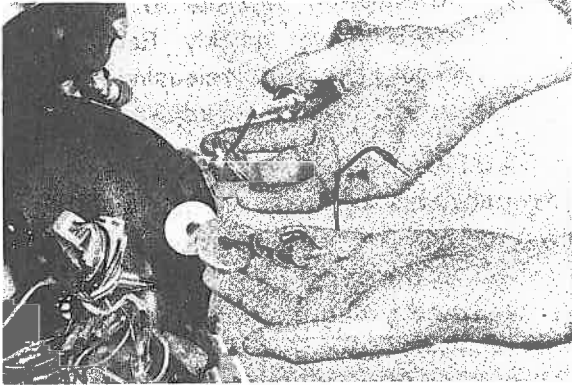

Connect all lead wires inside the headlight body. The wires of identical colors should be connected. (Some lead wires are excluded.)

**CONNECTION NOTE:** \_\_\_\_\_

The lead wires of the identical color must be connected to each other with the exception of the following #1 and #2 connections.

- #1. Left front flasher light lead wire B (Black) — Left wire harness lead wire Ch (Chocolate)
- #2. Right front flasher light lead wire B (Black) — Right wire harness lead wire Dg (Dark green)

When installing the headlight assembly, care should be used so that wires are not pinched. Secure the headlight assembly in place with the philips-head screw.

**Front footrest installation**

Fit the front footrest (right) with the rubber dampers (f-1), plate washers (f-2), spring washers (f-3) and cap nuts (f-4) in this order; then tighten the nuts.

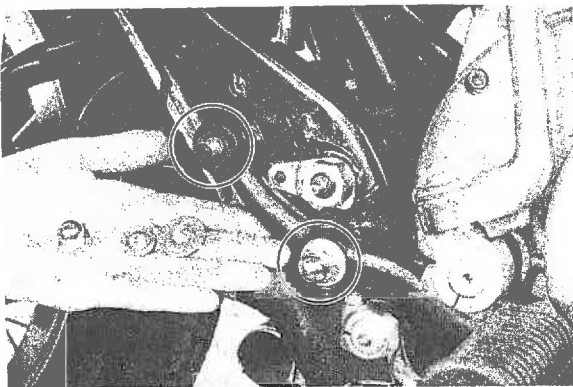

**Right-side muffler installation**

1. Remove first the right-side exhaust pipe holding nuts and then the exhaust pipe. Go on to remove the bolt that holds the pipe at one end.

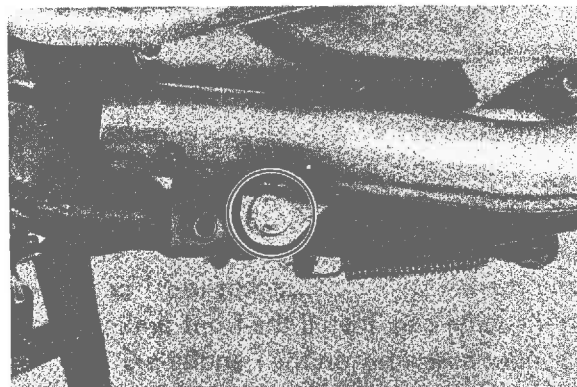
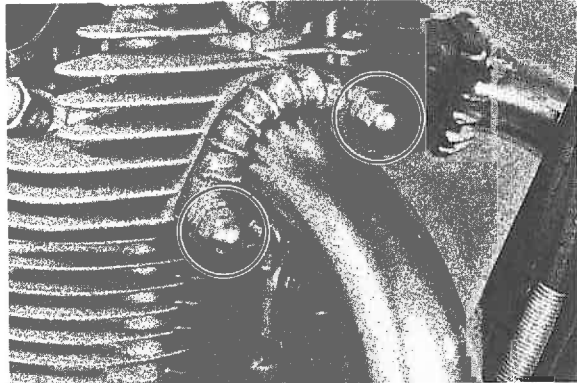

2. Install the right rear footrest to the right-side muffler with two bolts (a-1) and two spring washers (a-2) as shown in the photo.

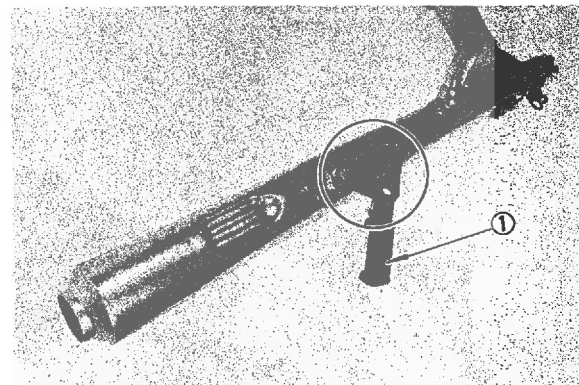

1. Rear footrest assembly (right-side)

3. Set the muffler band (a-3) over the exhaust pipe and insert the pipe into the muffler as shown. The locate the muffler in position with its connecting pipe and rear footrest bracket.

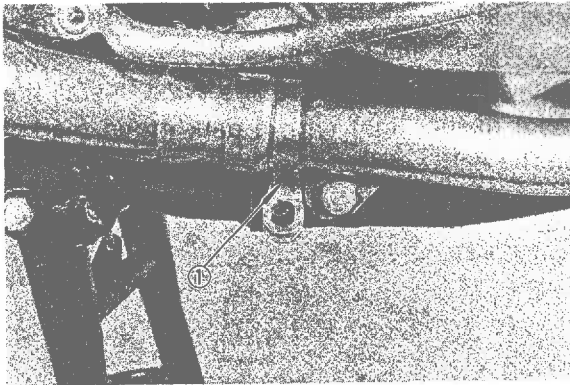

1. Muffler band

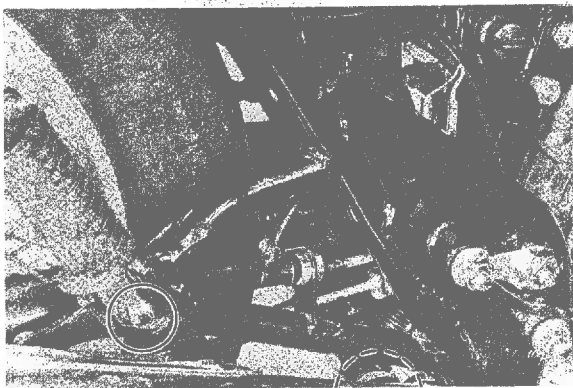

4. Proceed to tightening in the following sequence.
- a. Install the exhaust pipe and muffler joint into the cylinder head. Next, tightening the exhaust pipe holding nuts.

**NOTE:**

Before installing the exhaust pipe, make sure that the muffler gasket is fitted in place.

Tightening Torque:  
4.0 m-kg (28.9 ft-lb)

- b. Tighten the rear footrest bracket with a self locking nut (g-2) and plate washer (g-1).

Tightening Torque:  
4.5 m-kg (32.6 ft-lb)

- c. Where the exhaust pipe and right-side muffler are connected:
  - 1) Tighten the ring nut.
  - 2) Tighten the exhaust pipe as one end with the bolt and washer.

Tightening Torque:  
4.0 m-kg (28.9 ft-lb)

- 3) Tighten the bolt with washers (a-4) and muffler band are fitted.

Tightening Torque:  
4.5 m-kg (32.6 ft-lb)

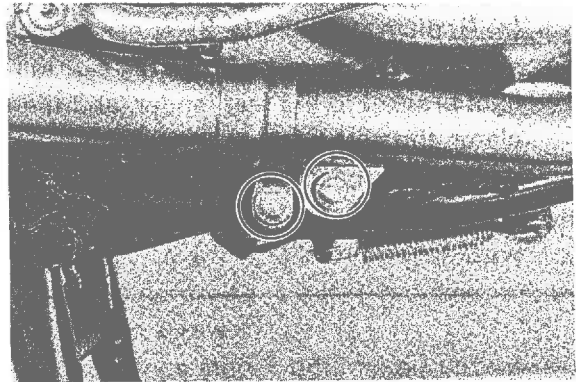

- 4) Tighten the bolt with the washer as shown in photo.

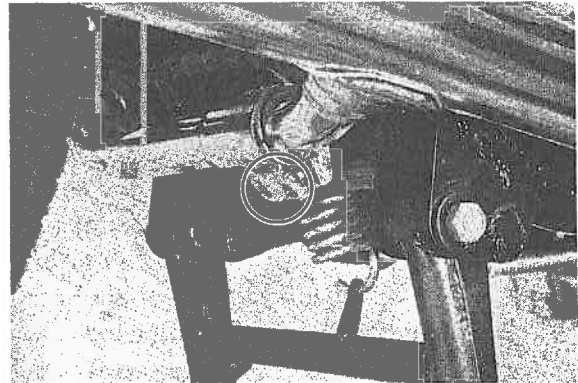

**Installation of taillight assembly and rear flasher light**

Install the electrical equipment items A and B as illustrated below.

**A. Taillight assembly**

1. Fit the grommet (n-1) and damper (n-9) to the taillight bracket.

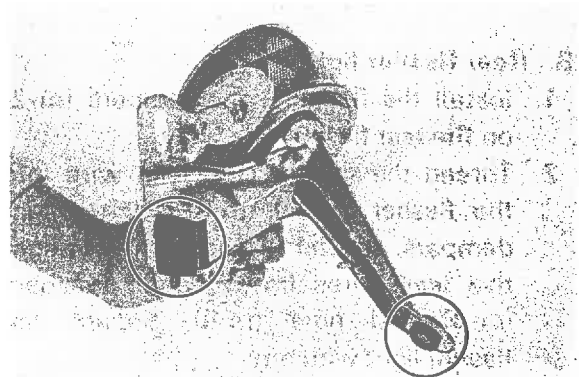

2. Pass the taillight wire harness through the taillight bracket, and connect to the taillight lead wires with the identical color.
3. Using bolt (n-4), plain washer (n-3), collar (n-2), nut (n-5), shoulder bolts (n-7), plain washers (n-8), spring washers (n-6) and nuts (n-5), install the taillight bracket to the rear fender, and then clamp the wire harness.
4. Fit the number support to the taillight bracket with suitable bolts, spring washers and nuts.

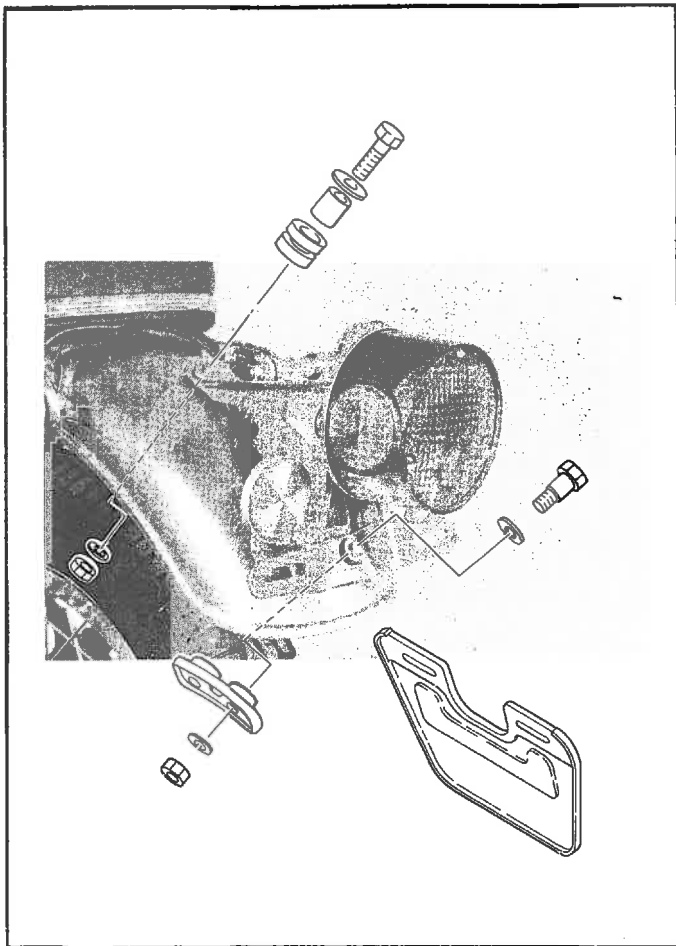

#### B. Rear flasher light

1. Install the flasher light dampers (m-2) on the rear flasher light stay.
2. Thread the flasher light lead wire into the flasher collars (m-3), flasher light dampers, special washers (m-6), negative lead wires (m-1), spring washers (m-4) and nuts (m-5). Secure the flasher light with nut.

#### NOTE:

Install the lead wire with the chocolate color marker on the left side. Next, install the other flasher light with a dark green marker on the right side.

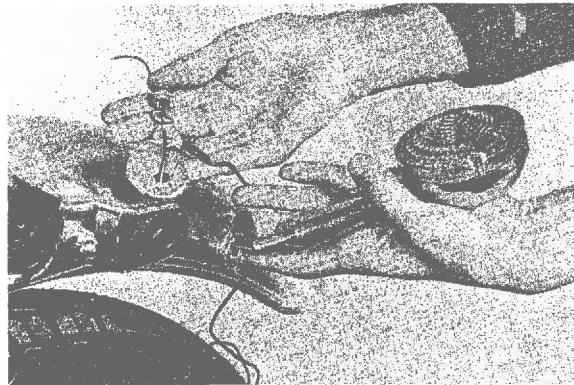

3. Connect the flasher light lead wire and negative lead wire to the wire harness and then clamp.

#### Seat installation

1. Install the seat bracket (c-6) to seat with bolts (c-7).

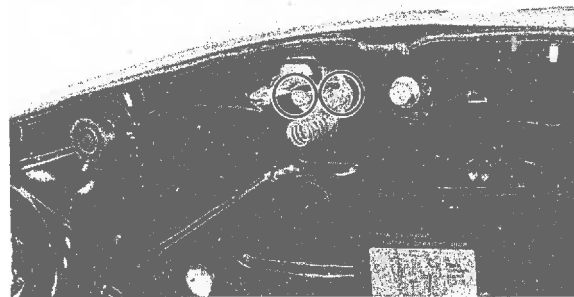

2. Secure the seat using the clip (c-2), clevis pins (c-1), bolts (c-5), spring washer (c-4) and stopper (c-3) as shown in the photo.

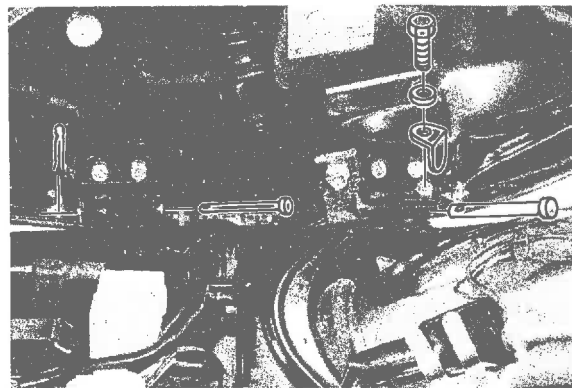

## ADJUSTMENTS — PRE-DELIVERY SERVICE

The following adjustments must be made before delivery of the motorcycle to a customer. Use the check list to mark off each operation when it is complete. The Check List is available at no charge from YPDI in pads of 50 sets. (P/N LIT-11161-00-78)

### Check the brake fluid level

Insufficient brake fluid may allow air to enter the brake system, possibly causing the brake to become ineffective. Check the brake fluid level and replenish when necessary and observe these precautions:

1. Use only the designated quality brake fluid; otherwise, the rubber seals may deteriorate, causing leakage and poor brake performance.

Recommended brake fluids:  
DOT No. 3

2. Refill with the same type and brand of brake fluid; mixing fluids may result in a harmful chemical reaction and lead to poor performance.
3. Be careful that water or other contamination does not enter the master cylinder when refilling. Water will significantly lower the boiling point and may result in vapor lock.

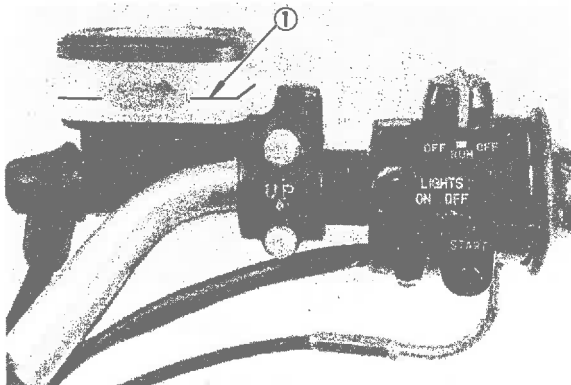

1. Lower level

### Air bleeding

#### CAUTION:

If the brake system is disassembled or if any brake hose has been loosened or removed, the brake system must be bled to remove air from the brake fluid. If the brake fluid level is very low or brake

operation is incorrect, bleed the brake system.

1. Add proper brake fluid to the reservoir. Install the diaphragm, being careful not to spill or overflow the reservoir.
2. Connect the clear plastic tube tightly to the caliper bleed screw. Put the end of the tube into a container.
3. Slowly apply the brake lever several times. Pull in lever. Hold lever in "on" position. Loosen bleed screw. Allow the lever to travel slowly toward its limit. Just before the limit is reached, tighten bleed screw.
4. Continue step 3 until all air bubbles are removed from system.

#### NOTE:

If bleeding is difficult, it may be necessary to let the brake system stabilize for a few hours. Repeat bleeding procedure.

5. Discard discharged brake fluid.

### Front brake adjustment

The front brake lever should be so adjusted that it has a free play 5 ~ 8 mm (0.2 ~ 0.3 in) at the lever end.

1. Loosen the lock nut on the brake lever.
2. Turn the adjuster so that the brake lever movement at the lever end is 5 ~ 8 mm (0.2 ~ 0.3 in) before the adjuster contacts the master cylinder piston.
3. After adjusting, tighten the lock nut.

#### NOTE:

Check for correct play and make sure it is working properly.

Free play: 5 ~ 8 mm (0.2 ~ 0.3 in)

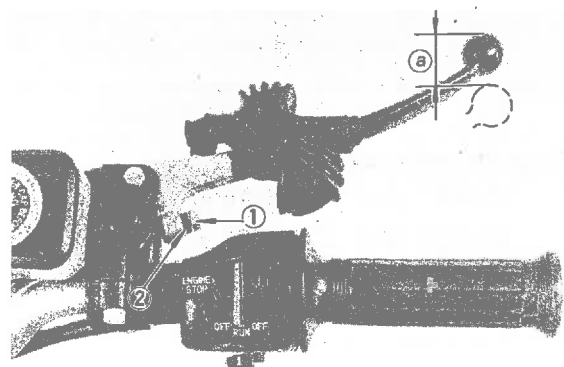

1. Adjuster 2. Lock nut a. 5 ~ 8 mm (0.2 ~ 0.3 in)

### Rear brake adjustment

The rear brake should be adjusted so the end of the brake pedal moves 20 ~ 30 mm (0.8 ~ 1.2 in).

1. To adjust, turn the adjuster nut on the brake rod clockwise to reduce play; turn the nut counterclockwise to increase play. Check whether or not the brake light operates correctly after adjusting.

#### NOTE:

Rear brake pedal adjustment must be checked any time the chain is adjusted or the rear wheel is removed and then reinstalled.

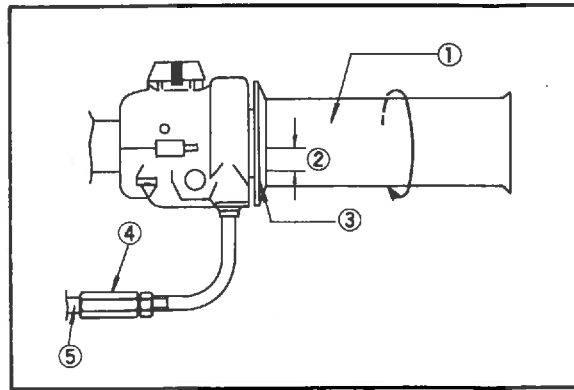

- |   |                  |
|---|------------------|
| 1. Throttle grip                            | 3. Grip flange   |
| 2. Turning play<br>5 ~ 10 mm (0.2 ~ 0.4 in) | 4. Adjusting nut |
|   | 5. Throttle wire |

### Drive chain tension check

#### NOTE:

Before checking and/or adjusting, rotate rear wheel through several revolutions and check tension several times to find the tightest point. Check and/or adjust chain tension with rear wheel in this "tight chain" position.

Inspect the drive chain with both tires touching the ground. Check the tension halfway between drive and driven sprockets. The normal vertical deflection is approximately 20 ~ 30 mm (0.8 ~ 1.2 in). If the deflection exceeds 20 ~ 30 mm (0.8 ~ 1.2 in) adjust the chain tension.

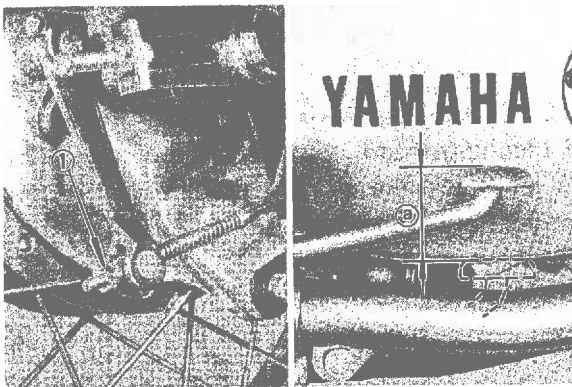

1. Adjusting nut a. 2 ~ 3 mm (0.08 ~ 0.12 in)

### Clutch adjustment

Loosen the handlebar lever adjuster lock nut. Next, turn the length adjuster either in or out until proper lever free play is achieved.

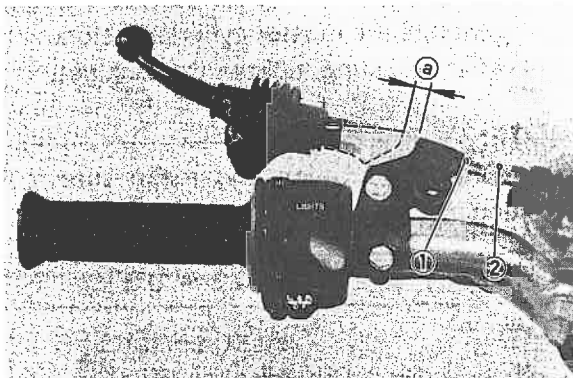

a. 20 ~ 30 mm (0.8 ~ 1.2 in) 1. Lock nut 2. Adjuster

### Throttle cable adjustment

1. Check play in turning direction of throttle grip. The play must be in the range of 5 ~ 10 mm (0.2 ~ 0.4 in) at grip flange.
2. If the play exceeds 10 mm (0.4 in) adjust with adjusting nut on throttle cable.

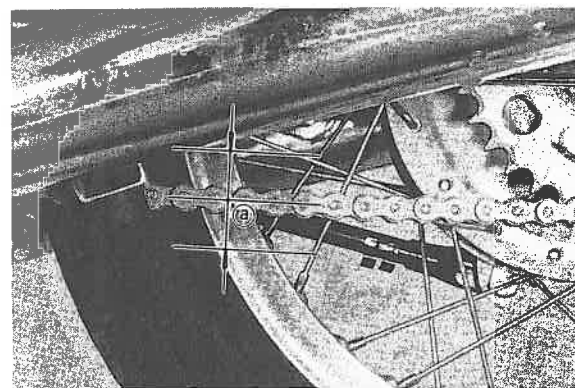

a. 20 ~ 30 mm (0.8 ~ 1.2 in)

### Drive chain tension adjustment

1. Loosen the rear brake adjust nut.
2. Remove the cotter pin of the rear wheel axle nut with pliers.
3. Loosen the rear wheel axle nut.
4. Loosen the lock nuts on each side. To tighten chain turn chain puller adjusters clockwise. To loosen chain turn



adjusters counterclockwise and push wheel forward. Turn each adjuster exactly the same amount to maintain correct axle alignment. (There are marks on each side of rear arm and on each chain puller; use them to check for proper alignment.)

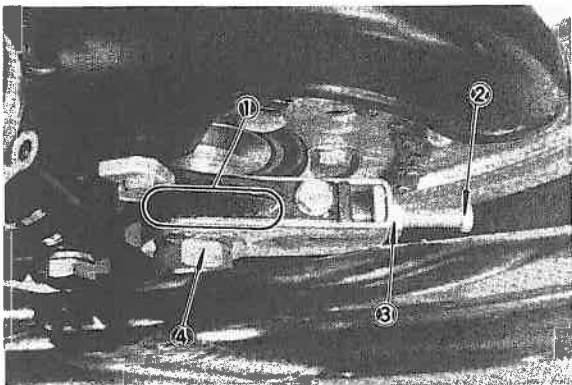

1. Marks for align  
2. Adjuster  
3. Lock nut  
4. Rea wheel axle nut

5. After adjusting, be sure to tighten the lock nuts and the rear wheel axle nut.
6. Insert the cotter pin into the rear wheel axle nut and bend the end of the cotter pin as shown in the illustration (if the nut notch and the cotter pin hole do not match, tighten the nut slightly to match).

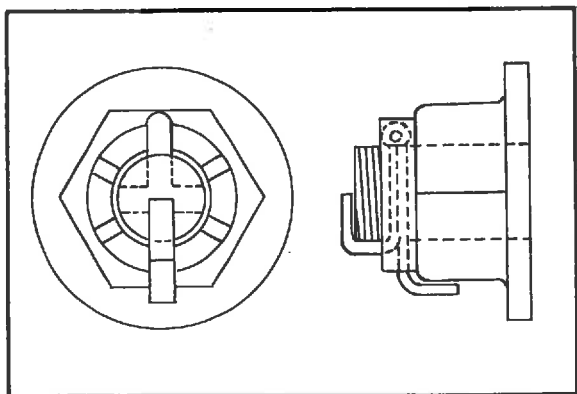

7. In the final step, adjust the play in the brake pedal.

**CAUTION:**

Excessive chain tension will overload the engine and other vital parts; keep the tension within the specified limits. Also replace the rear axle cotter pin with a new one.

**Tire pressure**

Check the tire pressure.

Cold tire pressure	Front	Rear
Normal riding	1.6 kg/cm <sup>2</sup> (22 psi)	2.0 kg/cm <sup>2</sup> (28 psi)
With passenger or High speed riding	2.0 kg/cm <sup>2</sup> (28 psi)	2.3 kg/cm <sup>2</sup> (32 psi)

**Headlight beam adjustment**

When necessary, adjust the headlight beam as follows:

1. Adjust horizontally by tightening or loosening the adjust screw.

To adjust to the right:  
Tighten the screw  
To adjust to the left:  
Loosen the screw

2. Adjust vertically as follows:
  - a. Loosen adjusting screw and adjust vertically by moving the headlight body.
  - b. Retighten the screw.

**Battery**

**CAUTION:**

Never try to add battery electrolyte (battery acid) to a battery that is installed on a machine. Even a skilled mechanic will spill enough acid to damage metal parts. Always remove the battery before filling with electrolyte and during charging. Always completely clean the exterior of the battery before re-installing.

1. The battery must be charged for the proper time. This initial charge will prolong the life of the battery.  
SEE TECHNICAL BULLETIN M7-075 FOR CHARGING DETAILS.
2. Electrolyte specific gravity.

Specific gravity at 20°C (68°F): 1.28

3. Filling the battery with diluted sulfuric acid (electrolyte).
  - a. Remove all filler caps from the battery, and remove the breather pipe cap at the same time.
  - b. Cool the electrolyte down to below 30°C (86°F).

- c. Pour electrolyte into each cell little by little up to the upper level line, and leave it for a while. When the battery fluid permeates the plates and separators, the fluid level begins to lower. Add electrolyte again.
- d. Charge the battery as required and measure the specific gravity of the fluid. Use a battery hydrometer of the single float type.
- e. Install the filler caps, and thoroughly wipe off the fluid around the filler caps. Wipe off the battery completely before installation.

**WARNING:**

Battery electrolyte is poisonous and dangerous, causing severe burns, etc. Contains sulfuric acid. Avoid contact with skin, eyes or clothing.

Antidote: **EXTERNAL**-Flush with water. **INTERNAL**-Drink large quantities of water or milk. Follow with milk of magnesia, beaten egg or veg. oil. Call physician immediately.

Eyes: Flush with water for 15 minutes and get prompt medical attention. Batteries produce explosive gases. Keep sparks, flame, cigarettes, etc., away. Ventilate when charging or using in enclosed space. Always shield eyes when working near batteries.

**KEEP OUT OF REACH OF CHILDREN.**

**Battery installation**

1. Make sure the main switch is turned off, and install the battery in the battery box. Connect the positive lead wire first, and then connect the negative lead wire.

**CAUTION:**

Make sure battery leads are connected properly. Reversing leads can seriously damage the electrical system.

2. The breather pipe should be connected as illustrated.

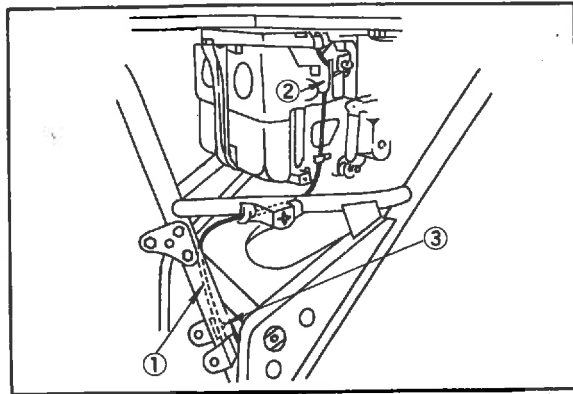

1. Right side
2. Pass through clamp 1. 2. 3.
3. Pass through clear space between bracket and engine

**Engine oil level measurement**

1. To check the level, warm the engine up for several minutes. Stop the engine. With the engine stopped, screw the dip stick completely out and then rest the stick in the hole.

**NOTE:**

When checking engine oil level with the dip stick, position the machine straight up and on main stand.



1. Oil level dip stick

2. The dip stick has a minimum and a maximum mark. The oil level should be between the two. If the level is low, add sufficient oil to raise it to the proper level.

**Fuel petcock cleaning**

1. Turn the petcock lever to the "ON" or "RES" position. Remove the fuel pipe.
2. Remove the drain cover and clean it with solvent.



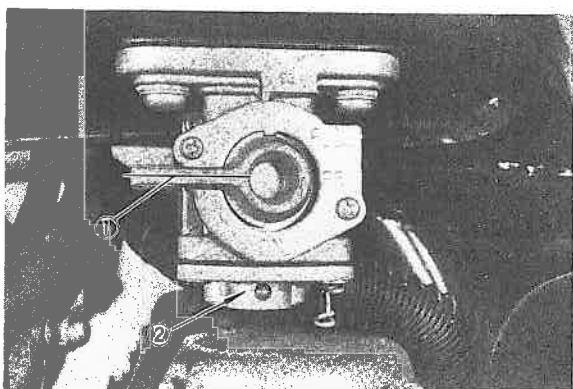

1. "RES" position 2. Drain cover

### Contact breaker

1. The contact breaker should be checked for the following:
  - a. Wear of the bakelite cam heel.
  - b. Damage of contact point surfaces.
  - c. Rust or wear on the breaker arm or arm shaft.
  - d. Faulty insulation of the contact breaker assembly.
  - e. Oil or dirt on the assembly.
2. To clean the points, run a point file between the points until the grey deposits and pits have been removed. Spray the points with ignition points cleaner or lacquer thinner, then snap the points shut on a white business card (or paper of hard texture) and repeatedly pull the card through until no more carbon or metal particles come off on the card. (The card may be dipped in lacquer thinner or other cleaner to facilitate this procedure.)
3. Point replacement should be necessary when the points become severely pitted, or if the heel is broken or worn unevenly, or if the points become shorted or show faulty operation.

**NOTE:** \_\_\_\_\_

New points must be cleaned and adjusted.

4. Adjust point gap (at widest opening) by moving the contact breaker assembly. Use filler gauge for this adjustment.

Point gap: 0.3 ~ 0.4 mm  
(0.012 ~ 0.016 in)

5. Add a few drops of light-weight machine oil onto the felt rubbing pad after

each point adjustment to lubricate the point cam surface. Do not over oil.

### Ignition timing

**NOTE:** \_\_\_\_\_

Point gap must be set before setting timing.

1. Ignition timing is checked with a timing light by observing the position of the stationary marks stamped on the stator and the pointer on the generator rotor.

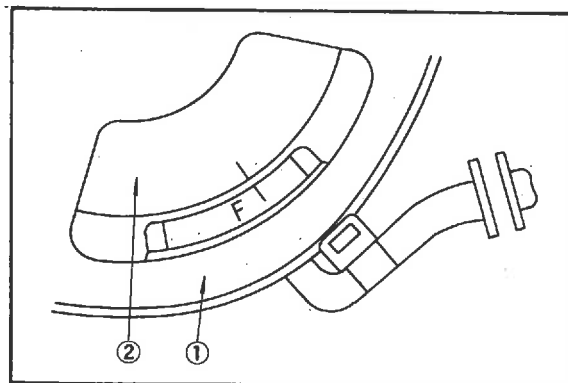

1. Stator  
2. Generator rotor

2. Connect timing light to right (left) cylinder spark plug lead wire. Ignition timing of right cylinder must be set first.
3. Start the engine and keep the engine speed as specified on the label. Use a tachometer for checking.
4. The rotor pointer should line up "F" stamped timing mark on the stator at a specified engine speed. If it does not align, loosen two breaker backing plate (breaker assembly holding) screws and move the complete backing plate (breaker assembly) until the point marks align.
5. Retighten screws. Check timing again for right cylinder.
6. Repeat procedure (steps 1-5) for left cylinder.

### Idle speed adjustment

1. Start the engine and warm it up for a few minutes.
2. Set the engine idle speed to specified speed on the label by turning the throttle stop screw in to increase the engine speed and back off the screw to decrease the engine speed. Use a tachom-

eter for checking and adjusting the engine speed.

### **Spark plugs**

1. Check electrode condition and wear, insulator color and electrode gap.
2. Use a wire gauge for adjusting the plug gap.
3. If the electrodes become too worn, replace it.
4. When installing the plug, always clean the gasket surface, wipe off any grime that might be present on the surface of the spark plug, and torque the spark plug properly.

**Standard spark plug: N-7Y (CHAMPION)**

**Spark plug gap: 0.7 ~ 0.8 mm  
(0.028 ~ 0.031 in)**

**Spark plug tightening torque:  
2.0 m-kp (14.5 ft-lb)**

- MEMO -

# XS650E CABLE ROUTING

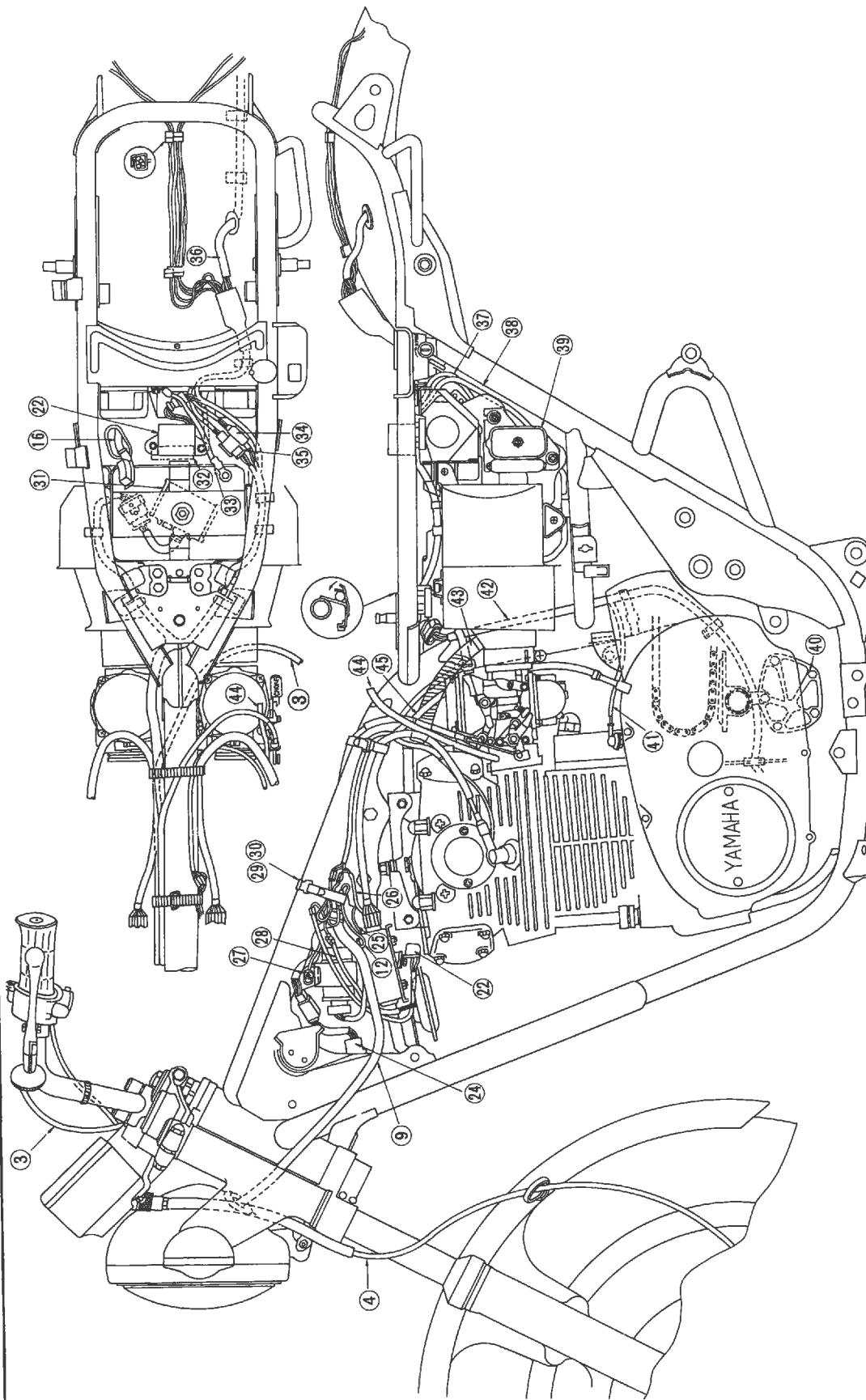

- |                                |                       |                               |                       |                           |                              |
|--------------------------------|-----------------------|-------------------------------|-----------------------|---------------------------|------------------------------|
| 1. Brake hose                  | 9. Wire harness (L)   | 17. Blue/White                | 25. Brown             | 33. Cord (-)              | 41. Neutral switch lead wire |
| 2. Throttle cable              | 10. Wire harness (R)  | 18. Red                       | 26. Condenser         | 34. Light checker coupler | 42. ACG Cord                 |
| 3. Clutch cable                | 11. Gray              | 19. Relay assembly            | 27. Diode             | 35. Regulator coupler     | 43. Breather pipe            |
| 4. Speedometer cable           | 12. Orange            | 20. Rear brake light switch   | 28. Flasher relay     | 36. Tail light lead wire  | 44. Vacuum pipe              |
| 5. Tachometer cable            | 13. Red/White         | 21. Horn                      | 29. Breaker lead wire | 37. Light checker wire    | 45. Fuel hose                |
| 6. Front stop switch wire      | 14. High tension cord | 22. Reserve lighting resistor | 30. Horn lead wire    | 38. Regulator wire        |                              |
| 7. Switch handle (R) lead wire | 15. Starter switch    | 23. Black                     | 31. Rectifier         | 39. Regulator             |                              |
| 8. Switch handle (L) lead wire | 16. Cord (+)          | 24. Flasher cancelling unit   | 32. Light checker     | 40. Starter motor cover   |                              |

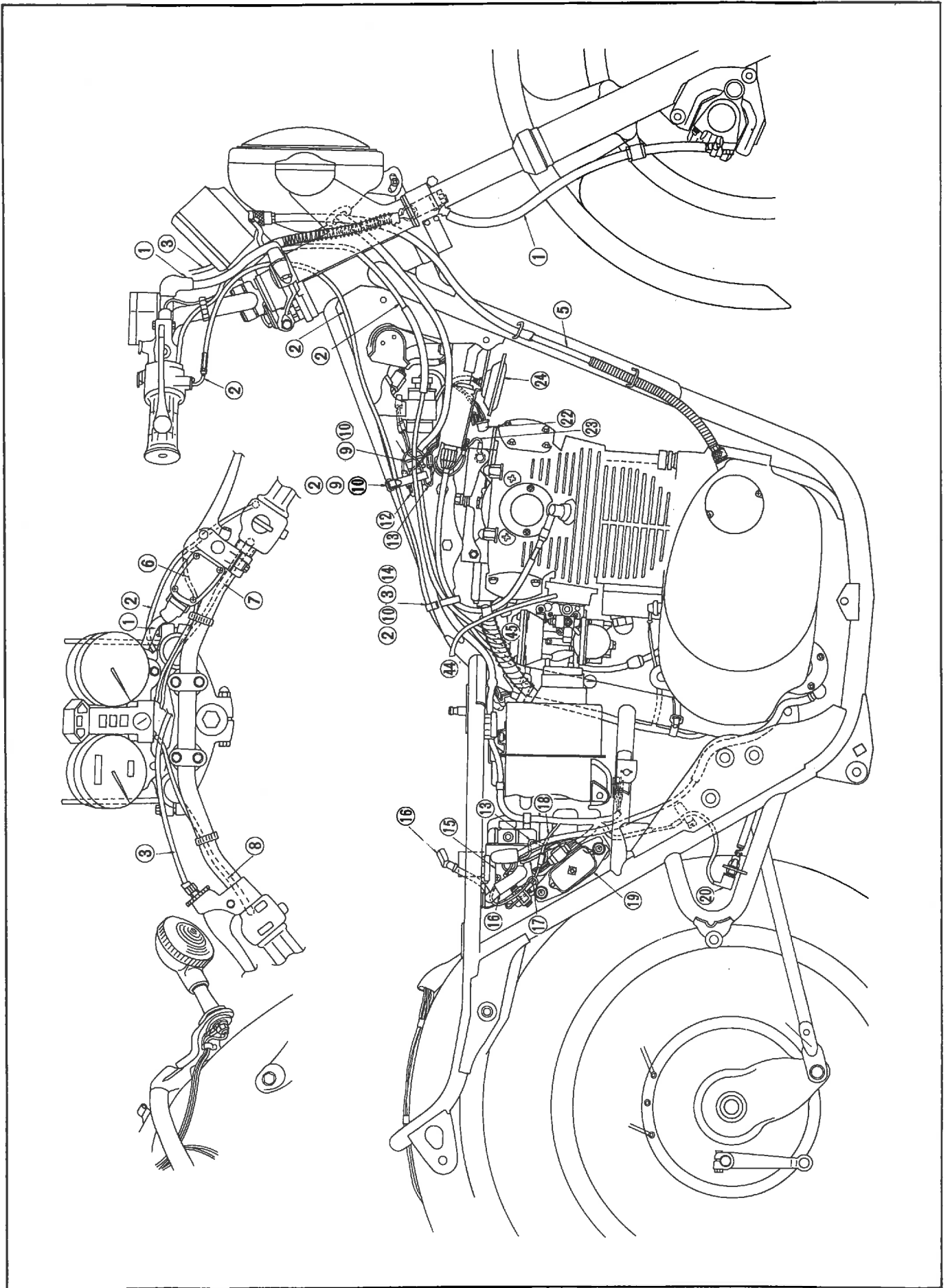

# XS650E WIRING DIAGRAM

COLOR CODE	
L/W . . . . .	Blue/White
R/W . . . . .	Red/White
L/B . . . . .	Blue/Black
L/Y . . . . .	Blue/Yellow
L/G . . . . .	Blue/Green
Y/B . . . . .	Yellow/Black
Br/W . . . . .	Brown/White
Y/R . . . . .	Yellow/Red
L/R . . . . .	Blue/Red
W/B . . . . .	White/Black
G/W . . . . .	Green/White
W/G . . . . .	White/Green
G/Y . . . . .	Green/Yellow
Y/G . . . . .	Yellow/Green
R . . . . .	Red
Br . . . . .	Brown
L . . . . .	Blue
Y . . . . .	Yellow
G . . . . .	Green
P . . . . .	Pink
B . . . . .	Black
Dg . . . . .	Dark green
Ch . . . . .	Chocolate
Sb . . . . .	Sky blue
W . . . . .	White
Gr . . . . .	Gray
O . . . . .	Orange
R/Y . . . . .	Red/Yellow
Lg . . . . .	Light green

- 1. Main switch
- 2. Handlebar switch right
- 3. Handlebar switch left
- 4. Starter switch
- 5. Engine stop switch
- 6. Headlight switch
- 7. Dimmer switch
- 8. Horn switch
- 9. Flasher switch
- 10. Key removal
- 11. Key removal
- 12. Tachometer
- 13. High beam
- 14. Meter light
- 15. Meter light
- 16. Pilot box
- 17. Headlight outage
- 18. Turn right
- 19. Turn left
- 20. Brake light
- 21. Neutral
- 22. Speedometer
- 23. Meter light
- 24. Meter light
- 25. Lead switch
- 26. Front brake switch
- 27. Rear brake switch
- 28. Safety relay
- 29. Light checker
- 30. Reserve lighting unit
- 31. Rear flasher light
- 32. Fuse
- 33. Battery
- 34. Starter switch
- 35. Starting motor
- 36. Ignition coil
- 37. Headlight
- 38. Front flasher light
- 39. A.C. Generator
- 40. Neutral switch
- 41. Rectifier
- 42. Regulator
- 43. Body earth
- 44. Cancelling unit
- 45. Horn
- 46. Flasher relay
- 47. Breaker
- 48. Condensor
- 49. Taillight
- 50. Spark plug

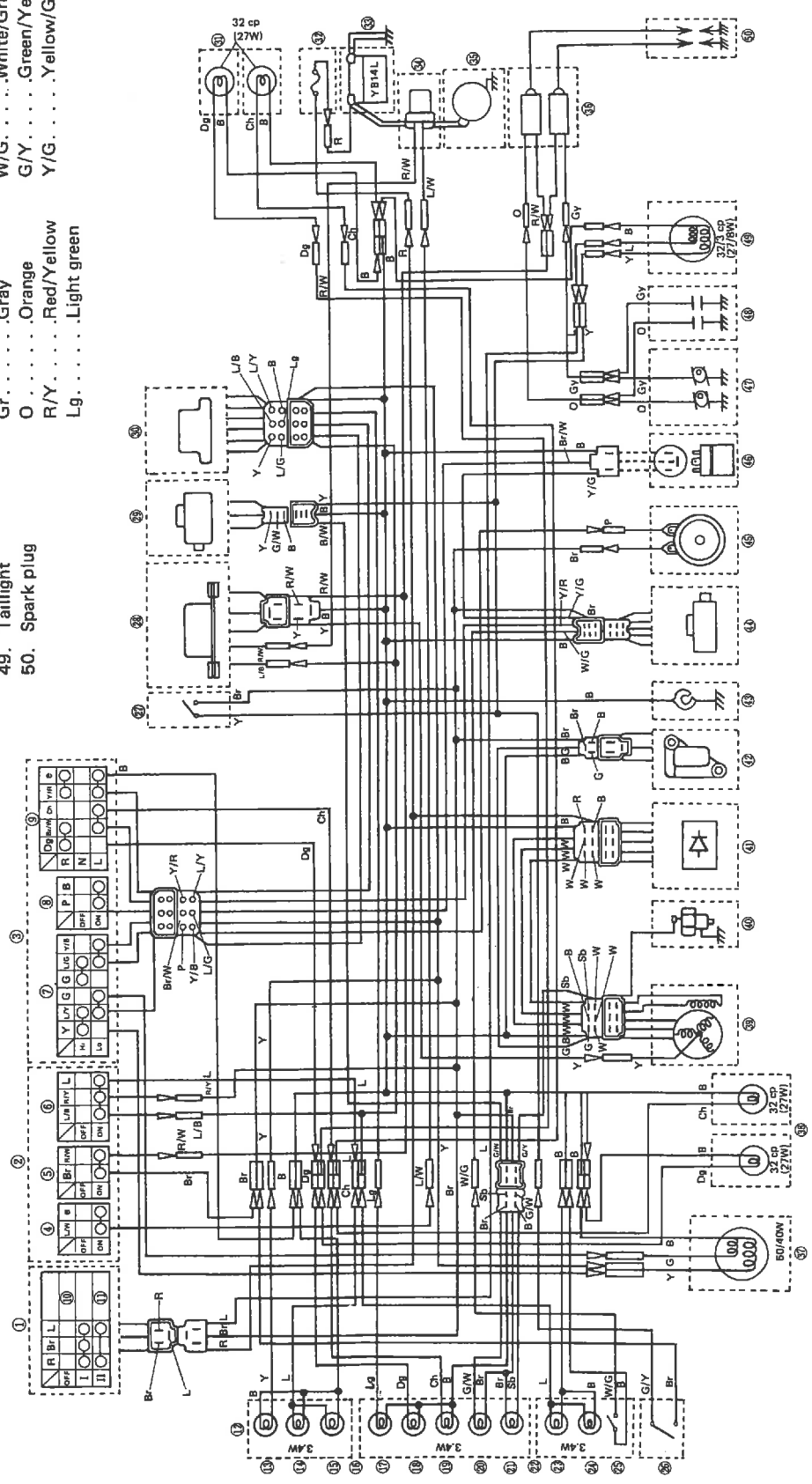



**YAMAHA MOTOR CO.,LTD.**

IWATA JAPAN

PRINTED IN JAPAN  
77 • 12 • 20 x 1 CR