

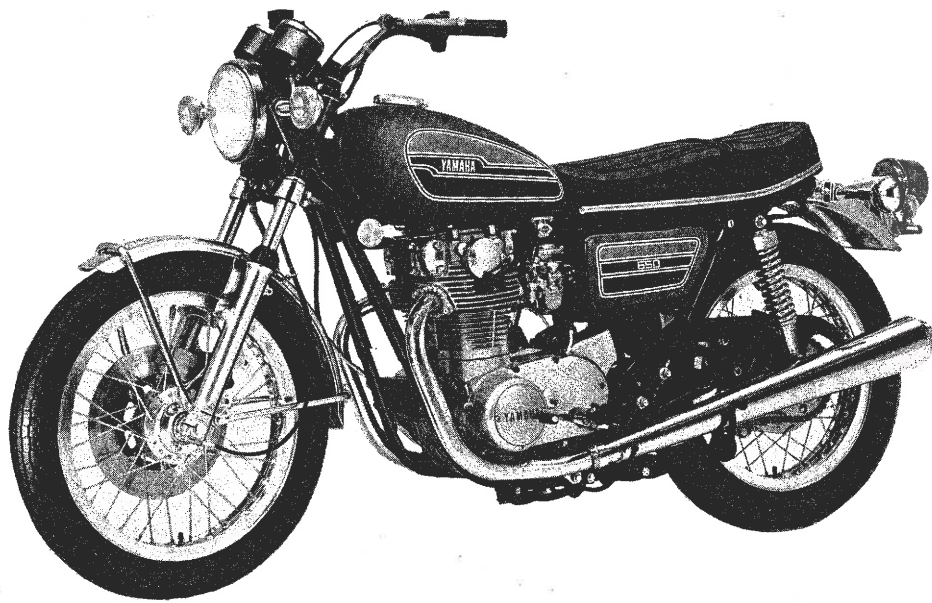

YAMAHA

XS650C



ASSEMBLY MANUAL

584-28198-10

FOREWORD

This Assembly Manual contains the information required for the unpacking and assembly of Yamaha motorcycles so that the Yamaha serviceman can assemble the machine in the correct manner. To perform machine assembly, a basic knowledge of service and Yamaha machines is required. Therefore, all Yamaha dealers are urged to make a full study on the service of Yamaha motorcycles using the relevant service manuals.

NOTICE

The service specifications given in this Assembly Manual are based on the model as manufactured. When this model may require improvements, the service specifications may be subject to change in the future. If any change is introduced into the specifications or service procedures, Yamaha dealers will be notified through technical service information to be published by Yamaha. The assembly procedure is described in the order that the mechanic should follow, and the correct service tools should be used in the correct manner. Failure to do this may result in poor performance and danger to the rider.

**YAMAHA XS650C
ASSEMBLY MANUAL
1st Edition, August, 1975
SERVICE DEPT.
OVERSEAS ENGINEERING DIVISION
YAMAHA MOTOR CO., LTD.**

CONTENTS

PREPARATION	1
Tools for unpacking	1
Tools for assembling	1
Supplies	2
Workshop	2
UNPACKING	2
Note on transportation	2
Procedure for unpacking	2
PARTS CHECK LIST	3
INSTALLATION GUIDE	7
SET-UP PROCEDURES	8
INSPECTIONS AND ADJUSTMENTS	21
Inspections	21
Adjustments	22
CABLE ROUTING	24

PREPARATION

To assemble the machine correctly, the following service tools, supplies and working space are required:

Tools for unpacking

1. Nail puller
2. Pliers
3. Steel hammer
4. Scissors

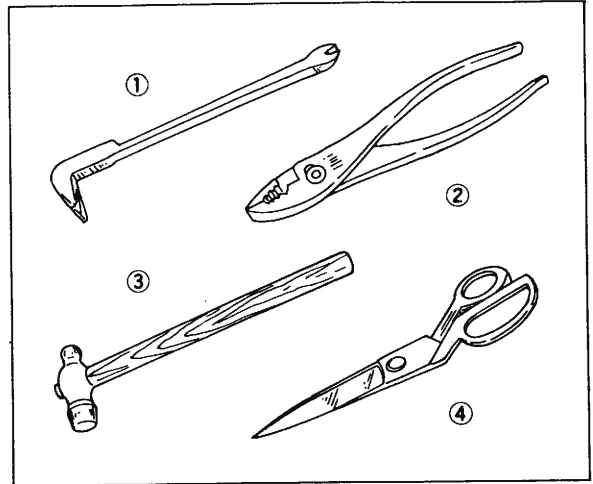

Tools for assembling

- | | | |
|---------------------------|--|----------------------------|
| 1. L-handle socket wrench | 6. Slotted head screwdrivers
(Large, medium and small) | 9. Long nose pliers |
| 2. Spark plug wrench | 7. Phillips head screwdrivers
(Large, medium and small) | 10. Allen wrench set |
| 3. Steel hammer | 8. Pliers | 11. T-handle socket wrench |
| 4. Soft-faced hammer | | 12. Socket wrench set |
| 5. Wrench set | | 13. Torque wrench |

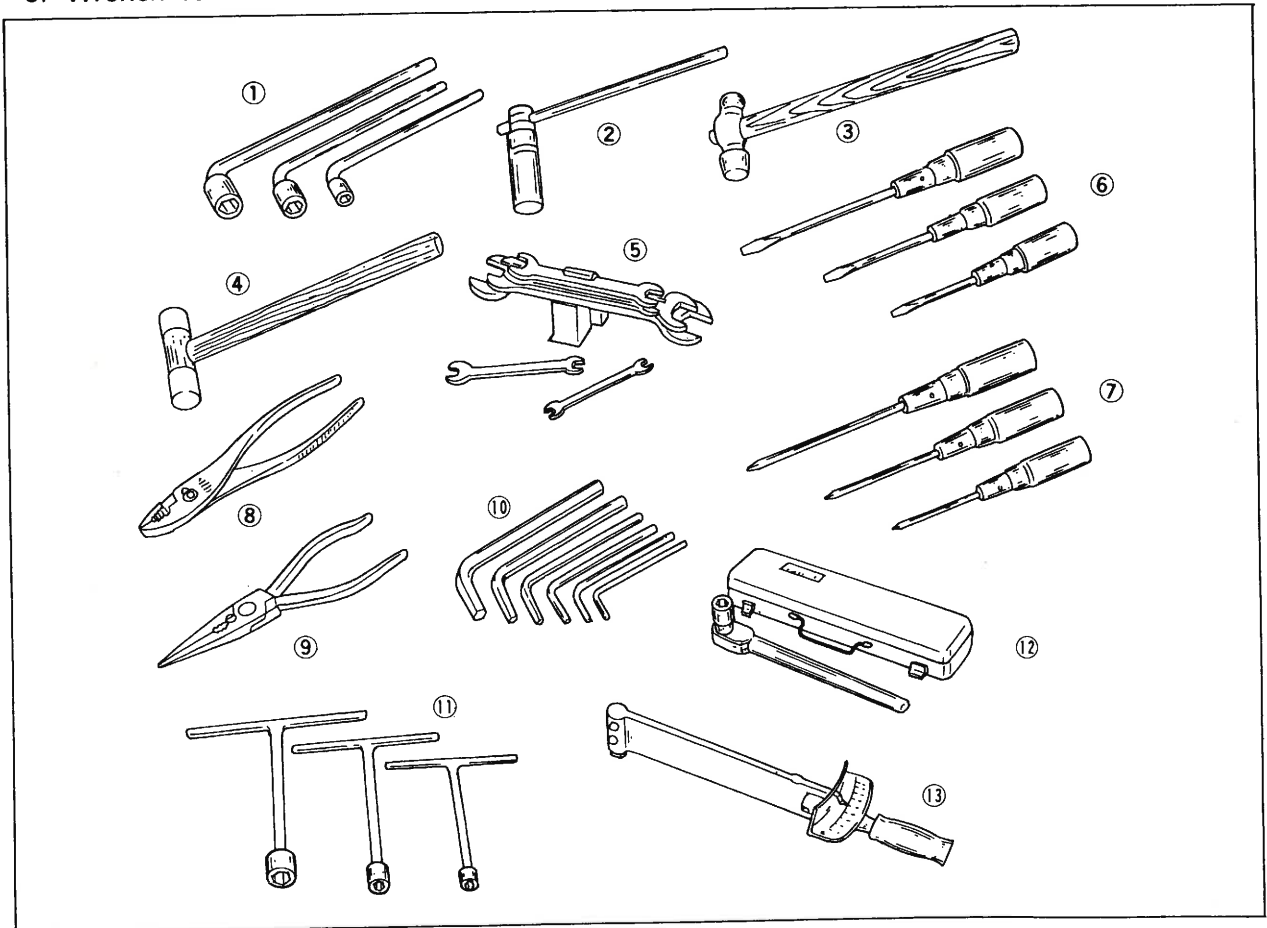

Supplies

Oils, greases, shop rags, electrical contact cleaner.

Workshop

The workshop where the machine is assembled should be clean and large. The floor should be level.

UNPACKING

Note on transportation

Use care not to butt the machine packed in the crate against a hard object or give it a heavy shock during transportation or in the service shop.

Procedure for unpacking

To remove the machine and parts packed in the cardboard crate, cut the vinyl bands around the box using a cutter or scissors. Next, remove the exterior carton by lifting it straight up.

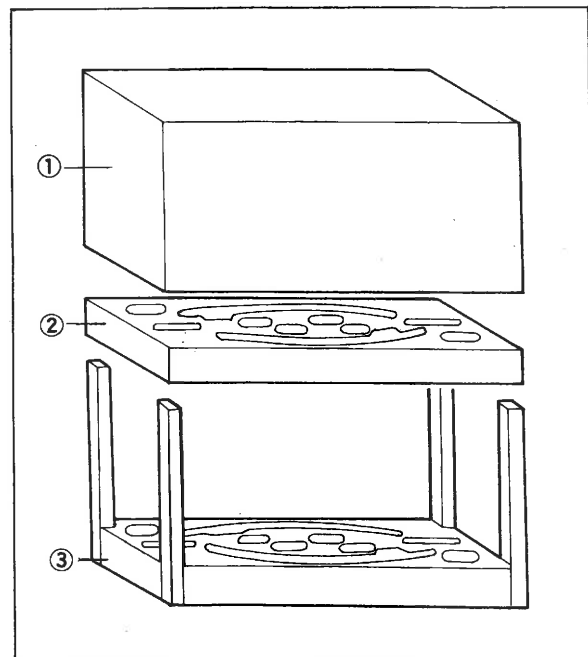

1. Cardboard crate
2. Upper foam tray
3. Lower foam tray

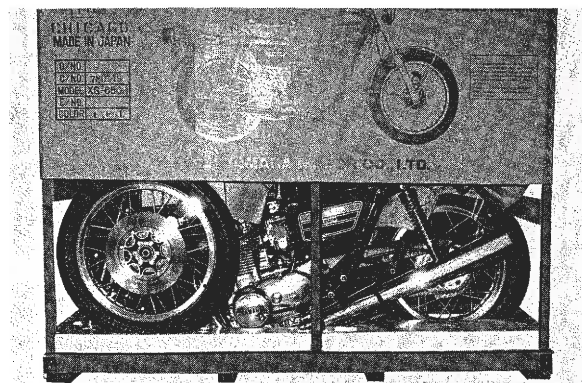

PARTS CHECK LIST

Before starting the assembly, check for damaged or missing (listed below). Also check the machine for damage, scratches and other defects.

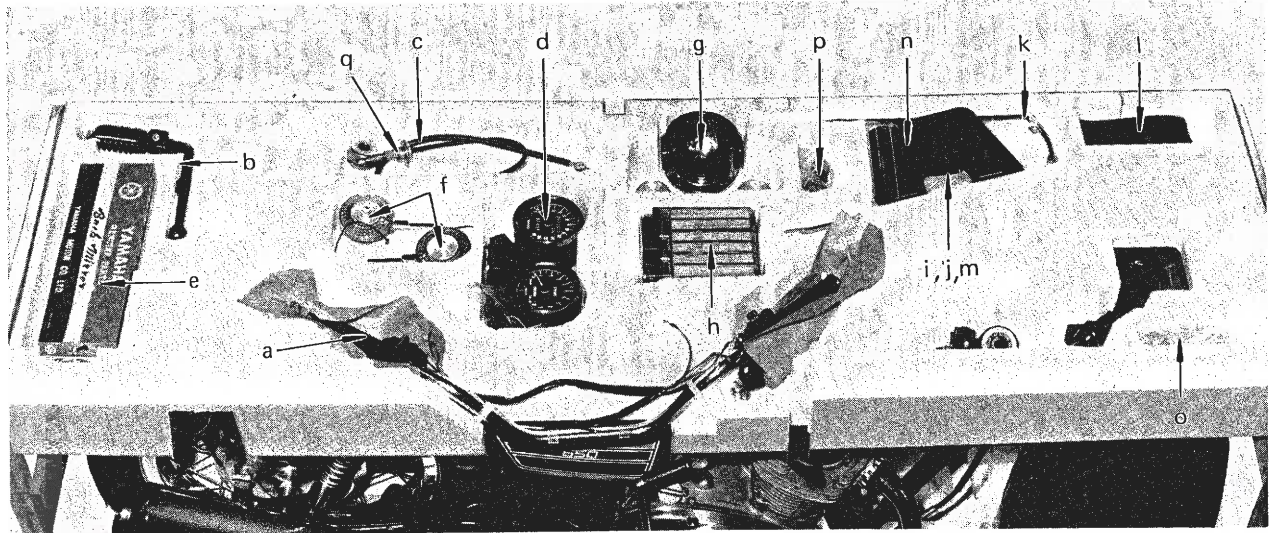

The following parts are contained in the foam tray and the vinyl bag in the package. Check the quantity of parts against the list. Also check for damage.

< Foam tray >





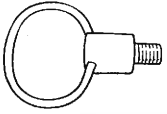
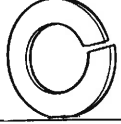
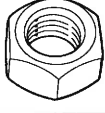
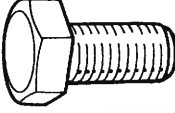

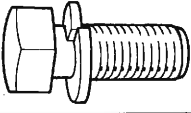
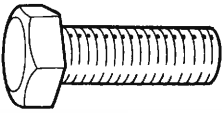
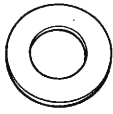
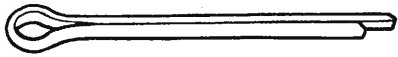
No.	Parts Name	Q'ty
a	Handlebar assembly	1
b	Right footrest assembly	1
c	Speedometer cable assembly	1
d	Meter assembly	1
e	Rear view mirror	1
f	Front flasher light	2
g	Tail/Stoplight assembly	1
h	Battery	1
i	Owner's Manual	1
j	Owner's warranty guide book	1
k	Front fender stay	2
l	Service tool	1
m	Battery seat	1
n	Number support	1
o	Vinyl bag (A and B)	1
p	Vinyl bag C	1
q	Front wheel axle collar	1



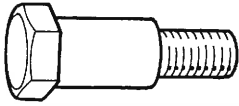
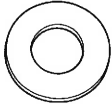

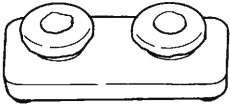
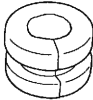
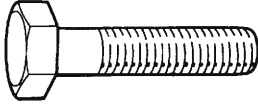
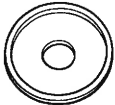

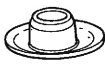
< Vinyl bag A >

No.	Illustration	Part Name	Q'ty
r-1		Negative lead wire	2
r-2		Wire holder	2
r-3		6 mm spring washer (Galvanized)	1
r-4		6 mm nut	1
r-5		6 mm bolt (ℓ = 12 mm)	6
r-6		6 mm spring washer (Chrome-plated)	10
r-7		8 mm bolt with spring washer	4
r-8		6 mm bolt (ℓ = 18 mm)	4
r-9		6 mm plain washer	4
r-10		Cotter pin	1

< Vinyl bag B >

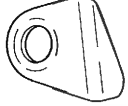
No.	Illustration	Part Name	Q'ty
r-11		Shoulder bolt	2
r-12		8 mm plain washer	2
r-13		6 mm spring washer	3
r-14		6 mm nut	3
r-15		Damper rubber	1
r-16		Damper rubber	1
r-17		6 mm bolt (ℓ = 25 mm)	1
r-18		Washer with rim	1
r-19		Fender mount collar	1
r-20		Bolt cap	6

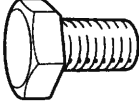
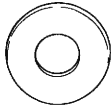
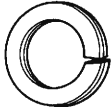
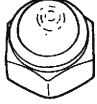
< Vinyl bag C >

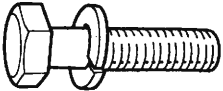
No.	Illustration	Part Name	Q'ty
s-1		Clevis pin	2
s-2		Clip	1
s-3		Stopper	1
s-4		6 mm spring washer	1
s-5		6 mm bolt	1
s-6		10 mm plain washer	2
s-7		10 mm spring washer	2
s-8		Crown nut	2
s-9		Lever holder	2
s-10		6 mm bolt with spring washer	2

INSTALLATION GUIDE

The removed parts should be installed in the positions indicated in the chart below:

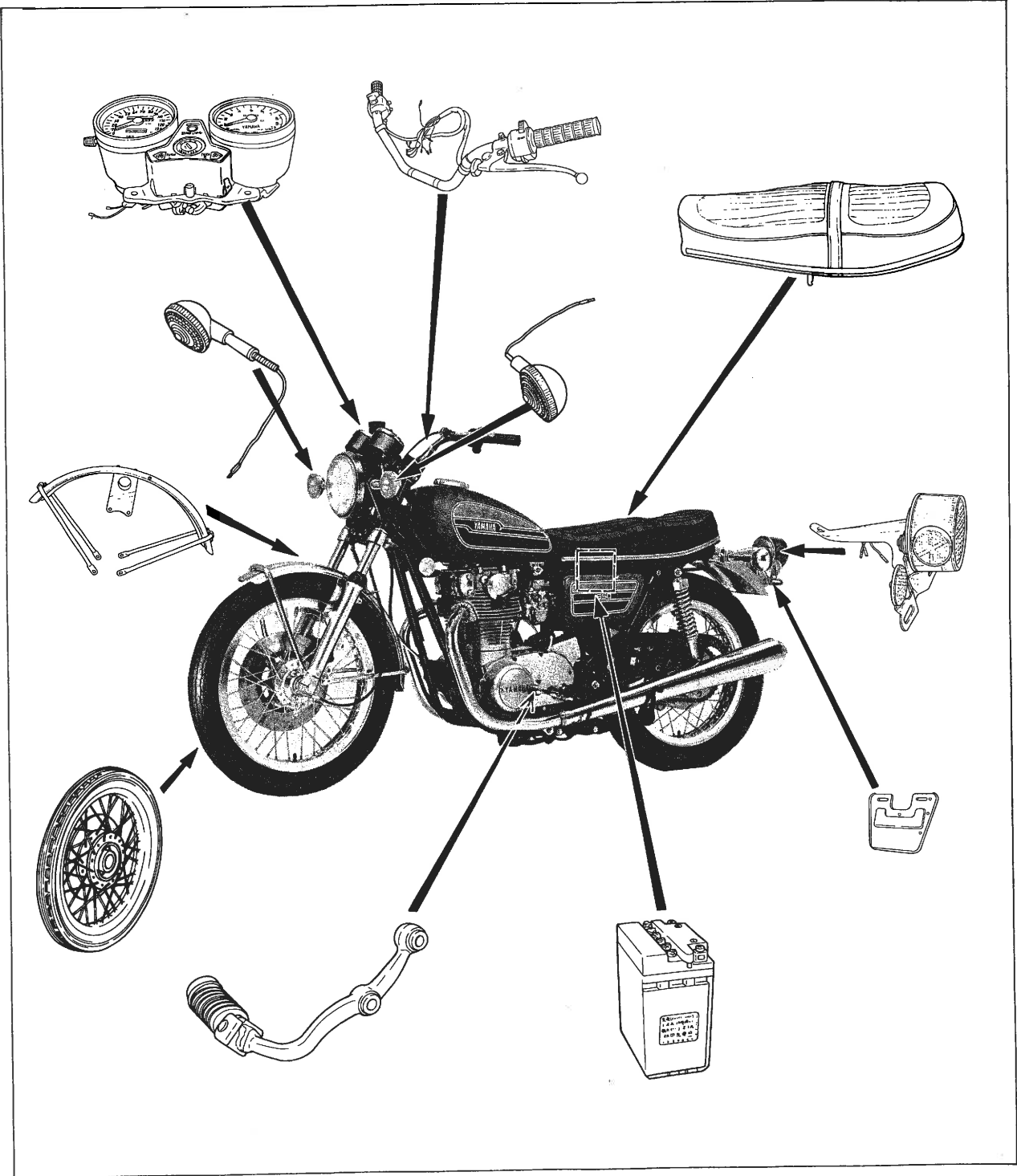

SET-UP PROCEDURES

Remove the front fender held between the rear tire and the rear fender. Next, remove the front wheel.

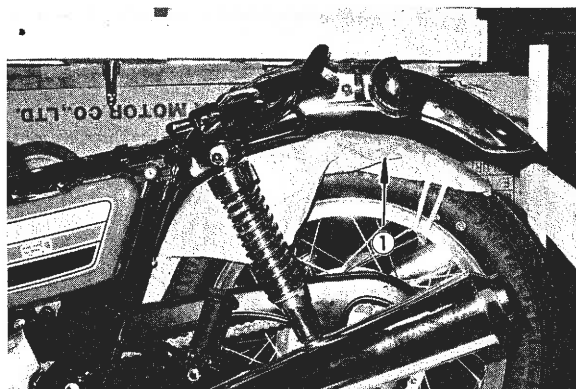

1. Front fender

Remove the seat and the front wheel.

Remove the nails from each corner of the crate, and remove the struts.

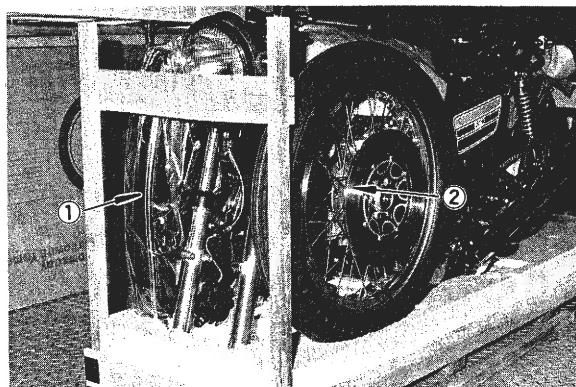

1. Seat 2. Front wheel

Lift up the machine, and remove the rear wheel section from the foam styrol base. Then take out the machine.

To install the front fender and front wheel, place a proper-size wooden box or a wooden block under the engine to keep the front of the machine raised off the floor. Take care so that the machine does not fall over.

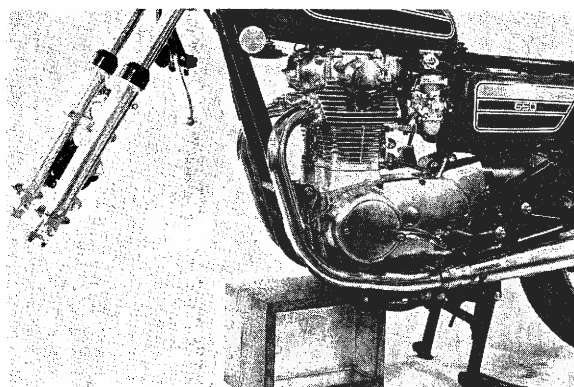

Insert the front fender between the front fork legs, and secure the fender using bolts with spring washers (r-7).

Tightening torque:

165 ~ 180 in-lb (1.9 ~ 2.1 m-k_g)

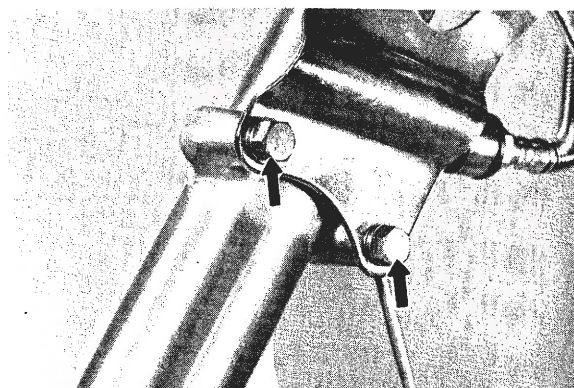

Using the spring washer (r-3) and nut (r-4) contained in the vinyl bag, install the wire holder (r-2) on the front fender.

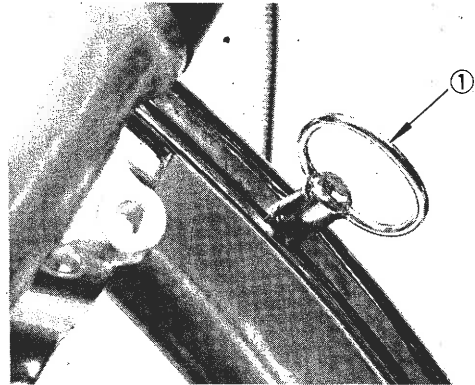

1. Wire holder

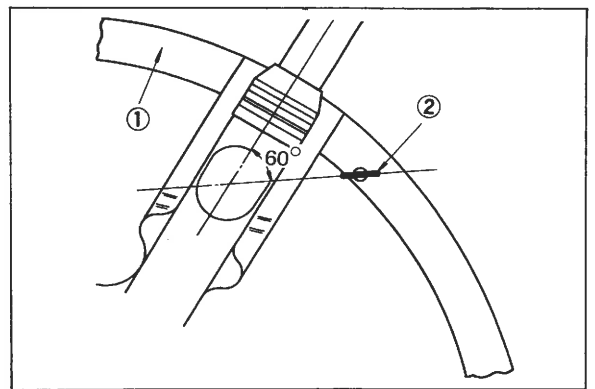

1. Front fender 2. Wire holder

Install the two front fender stays (k) on the front fender and the front forks.

1. At the front fork, use the bolts (r-8), spring washers (r-6) and plain washers (r-9).
2. At the front fork, use the bolts (r-8), spring washers (r-6) and plain washers (r-9).

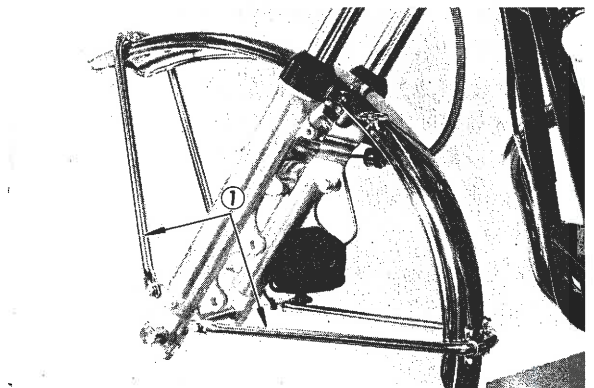

1. Front fender stay

Apply a light coat of grease to the speedometer drive gear and oil seal.

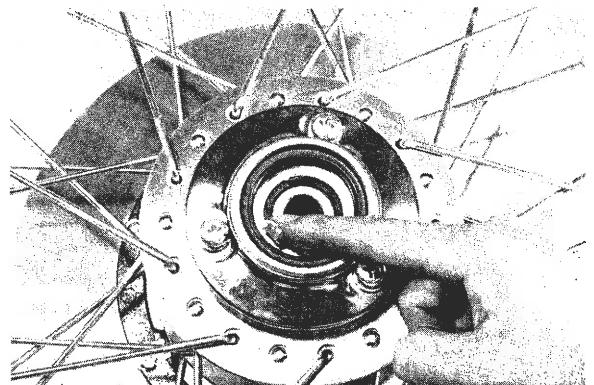

Remove the front wheel axle nut and plain washer, and loosen the two nuts securing the axle holder. Then remove the wheel axle.

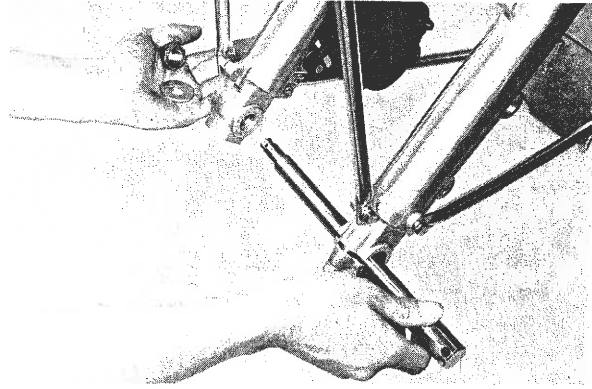

Install the wheel axle collar (q) in the wheel hub on the right side of the front wheel (disc side).

NOTE: _____
To avoid damaging the oilseal lip, apply a light coat of lithium base grease to the oilseal lip and axle collar. If the collar is dirty, clean with a rag.

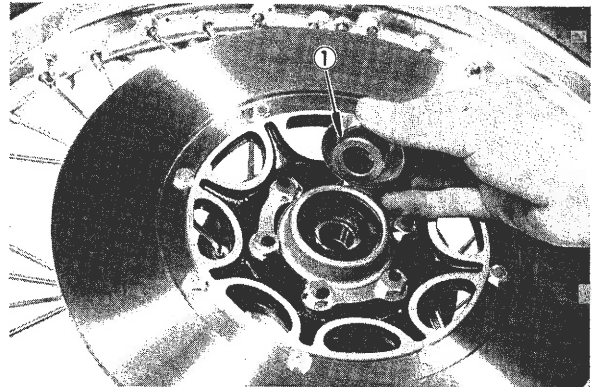

1. Wheel axle collar

Install the speedometer clutch assembly (c) on the left side of the front wheel.

1. Apply a light coat of lithium base grease to the oil seal lip on the front wheel side.
2. Apply a thin coat of lithium base grease to the meter drive gear and driven gear on the meter clutch side.
3. Make sure the two projections inside the wheel hub are meshed with the two slots in the speedometer clutch assembly.
4. Install the two disc pads in the disc brake caliper assembly.

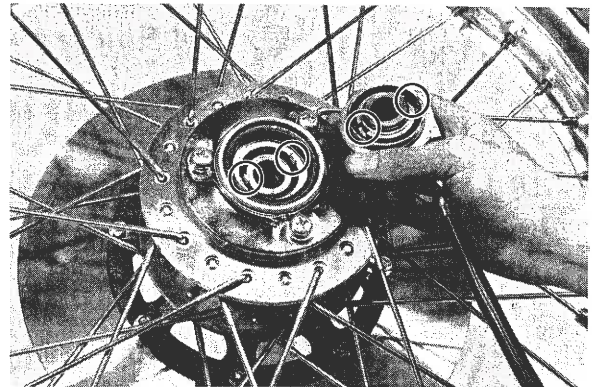

Install the front wheel on the front forks.

1. Make sure there is an enough gap between the disc pads, and check if the brake disc can be inserted between the disc pads by inserting from the front side of the machine. Then place the front wheel between the front fork legs.
2. Insert the wheel shaft from the left side of the wheel hub, mount the plain washer, and install the shaft nut. Before tightening the nut, position the meter

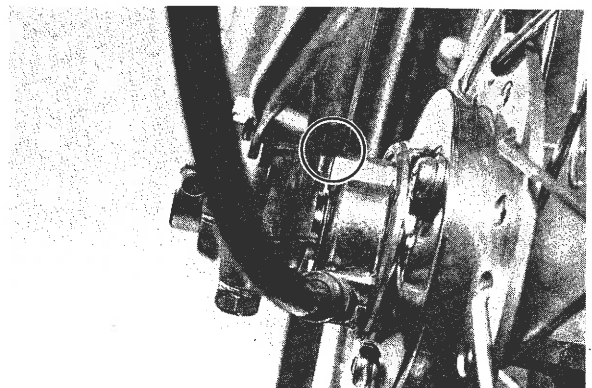

clutch assembly correctly as illustrated in the figure, and tighten the nut to specification.

Tightening torque:

53.5 ~ 75.0 in-lb (7.0 ~ 10.0 m-kg)

3. Lock the nut with the cotter pin (r-10). The pin should be inserted downward, and the pin ends should be bent.
4. Tighten the wheel shaft holder nut.

Tightening torque:

70 ~ 110 in-lb (0.8 ~ 1.3 m-kg)

CAUTION: _____

Tighten axle holder nuts in stages and maintain an equal gap on each side.

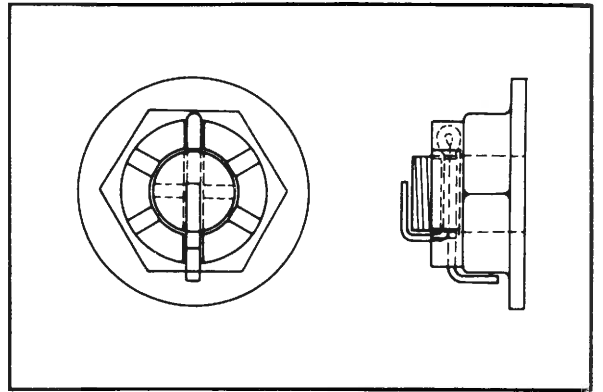

Remove the two Phillips-head anchor screws, one each, from the lower right and left parts of the headlight shell. Insert a slotted-head screwdriver between the shell and the lens assembly mounting ring on the bottom of the headlight shell, and pry out the lens assembly.

NOTE: _____

Care should be taken not to scratch the headlight shell with the slotted-head screwdriver. Also be careful not to lose any screw.

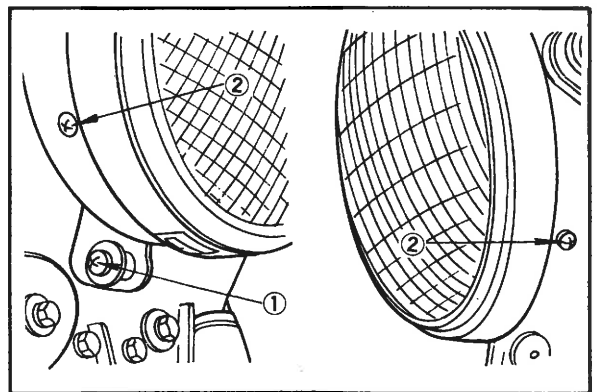

1. Holding screw
2. Anchor screw

Handlebar installation

1. Remove the four hexagon bolts, and remove the two handlebar holders.

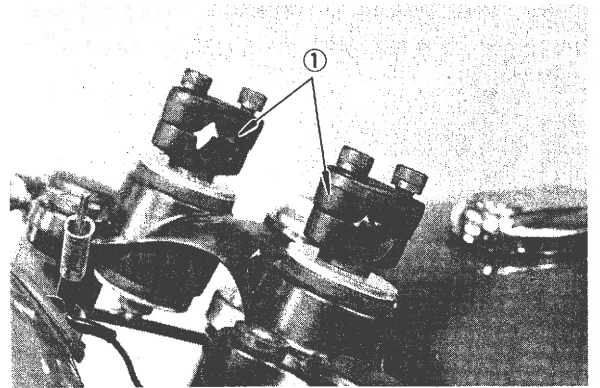

1. Handlebar holder

2. Insert the lead wire coming from the handle switch into the grommet attached to the headlight body.

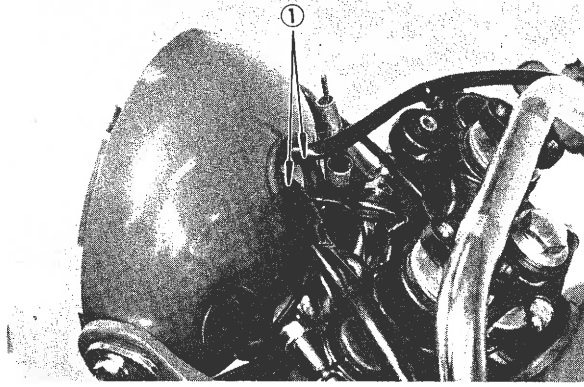

1. Lead wire

3. Install the handlebar using the two removed upper holders and four hexagon bolts.

Tightening torque:

160 ~ 230 in-lb (1.8 ~ 2.5 m-kg)

4. Install the four bolt caps (r-20).

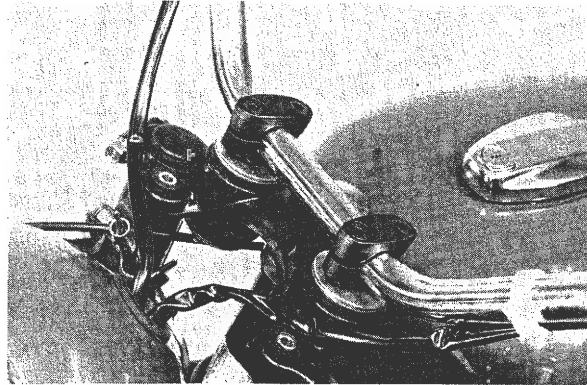

Meter bracket installation

Using the bolts and nuts contained in the vinyl bag (c), install the meter bracket assembly on the handle crown.

NOTE: _____

Before securing the meter bracket, all wires should be threaded through the headlight body grommet. Take care not to kink wires by pressure.

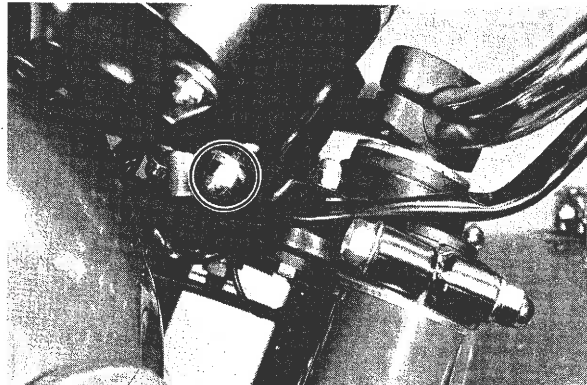

Throttle wire installation

1. Remove the two screws securing the right handle switch assembly, and separate the switch assembly into the upper and lower halves.

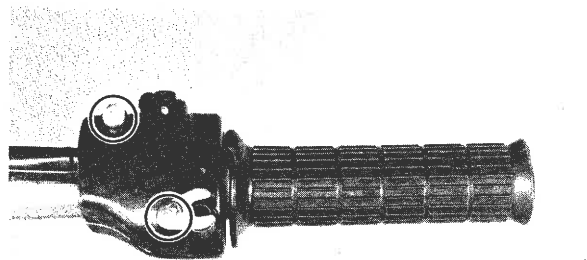

2. Thread the throttle wire through the hole in the lower handle lever holder. Hook the throttle cable end into its seat in the throttle guide housing. Then, grease the throttle cable and handle lever holder. Next, bolt the upper and lower handle lever holders together, and check the accelerator grip for smooth action.

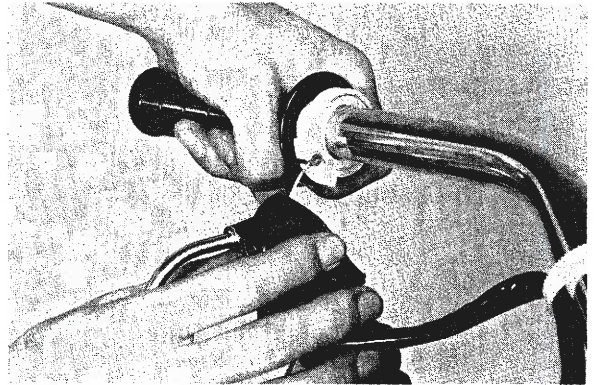

IMPORTANT: _____
The play in turning direction of the throttle grip must be adjusted to prevent the throttle wire from slipping off the throttle wire holder.

Throttle wire adjustment

1. Check play in turning direction of throttle grip. The play must be in the range of 0.20 ~ 0.40 in (5 ~ 10 mm) at grip flange. (Measuring point is optional.)
2. If the play exceeds 0.40 in (10 mm) adjust with adjusting nut on throttle wire 2 side.
3. If adjustment is impossible with the adjusting nut (because distance "A" must be maintained more than 0.16 in (4 mm)), then use adjusting nut on throttle wire 1 side.

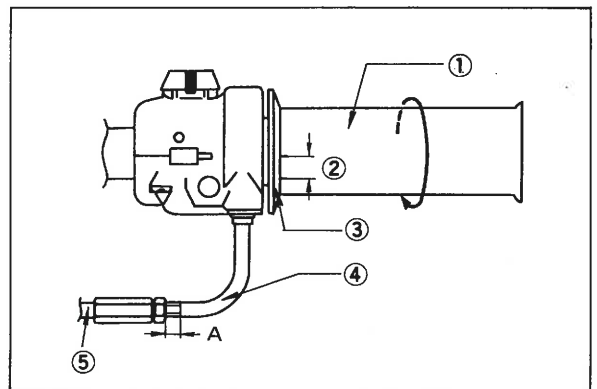

1. Throttle grip
2. Turning play 0.20 ~ 0.40 in (5 ~ 10 mm)
3. Grip flange
4. Throttle wire 2
5. Throttle wire 1

Using the bolts with spring washers (s-10) and lever holder (s-9) contained in the vinyl bag, install the front brake master cylinder assembly on the handlebars.

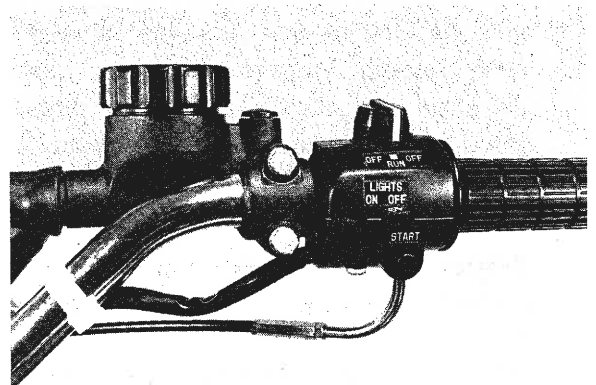

Connect the tachometer cable to the tachometer. For detailed cable routing, refer to illustration.

Connect the speedometer cable to the speedometer. For detailed cable routing, refer to illustration.

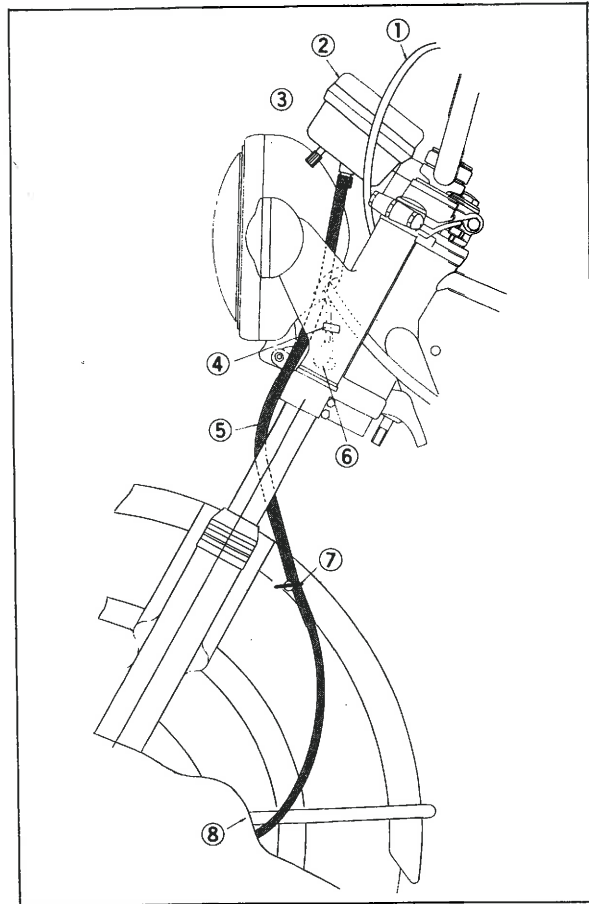

1. Clutch wire
2. Speedometer
3. Headlight
4. Clamp
5. Speedometer cable
6. Stop switch
7. Wire holder
8. Fender stay

Connect the clutch cable to the clutch lever (on the left part of the handlebar).

Clutch wire installation

1. Fully loosen the lever adjuster locknut, and screw in the adjuster until tight. Next, align the slit in the adjuster and adjuster locknut with the slit in the lever holder.
2. Insert the wire end into the lever hole, and hook the outer cable end onto the adjuster locknut, then squeeze the lever. Next, while pulling the outer cable in the direction opposite to the lever, release the lever quickly. While releasing it, seat the outer cable into the adjuster.

CAUTION:

Proper cable and wire routing is essential to insure safe vehicle operation. For details of the cable routing, refer to the cable routing diagram.

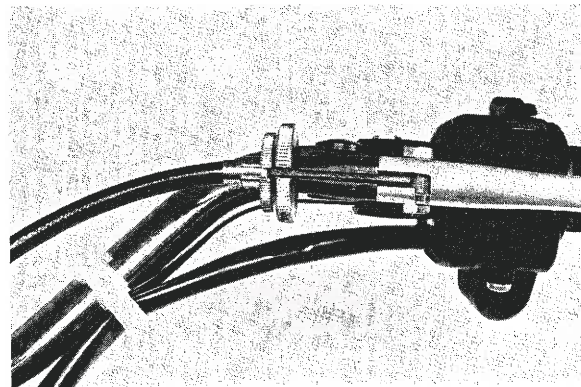

Install the rear view mirror assembly (e) on the left side of the handlebar. Adjust for proper rear view.

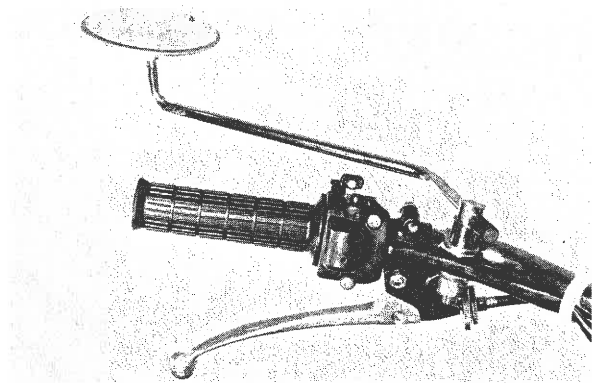

Front flasher lights installation

Install both right and left flasher light assemblies (f) to the headlight body through the stays, and install the negative lead wires (r-1) and spring washers as illustrated. Then tighten the nuts.

Connect all lead wires inside the headlight body. The wires of identical colors should be connected. (Some lead wires are excluded.)

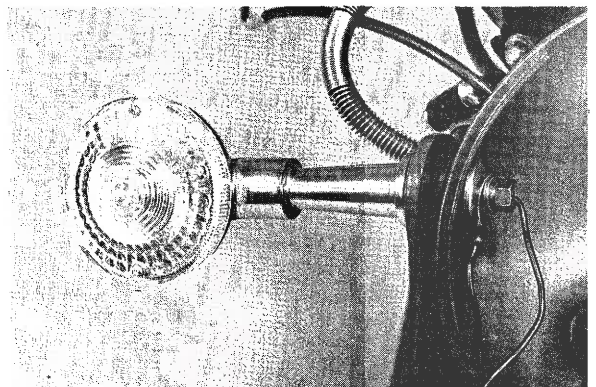

WIRE CONNECTION IN HEADLIGHT SHELL

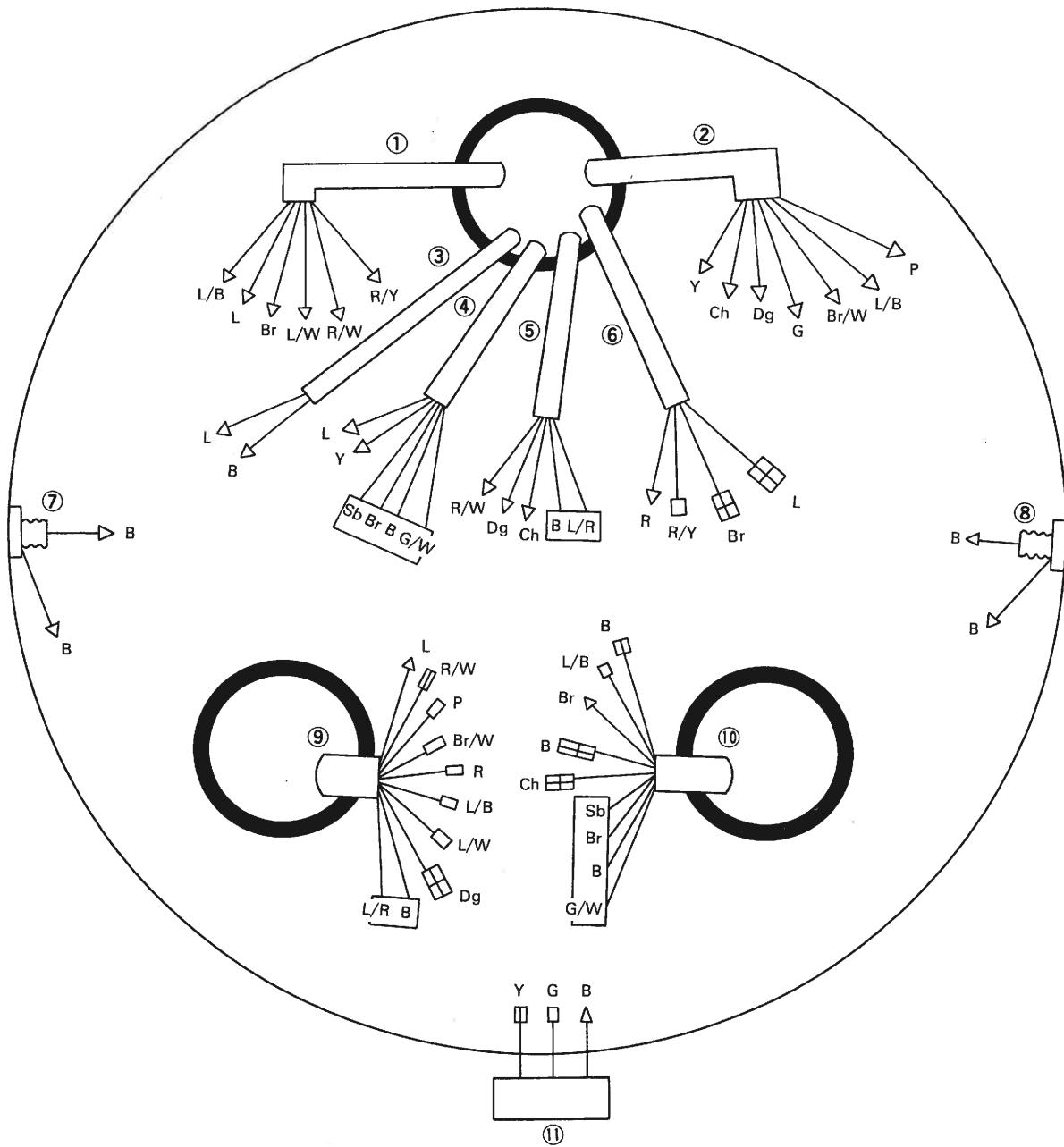

- | | | |
|---------------------------|---------------------------|----------------------------------|
| 1. From handle switch (R) | 5. From meter bracket | 9. From right wire harness |
| 2. From handle switch (L) | 6. From main switch | 10. From left wire harness |
| 3. From tachometer | 7. From flasher light (R) | 11. From headlight lens assembly |
| 4. From speedometer | 8. From flasher light (L) | |

CONNECTION NOTES FOR XS650C ASSEMBLY

The lead wires of the identical color must be connected to each other with the exception of the following #1 and #2 connections.

- #1. Left front flasher light lead wire B (Black) — Left wire harness lead wire Ch (Dark brown)
 #2. Right front flasher light lead wire B (Black) — Right wire harness lead wire Dg (Dark green)

Firmly fit the lens assembly in place. When installing the headlight lens assembly, care should be used so that wires are not pinched. Secure the headlight assembly in place with the Phillips head screw.

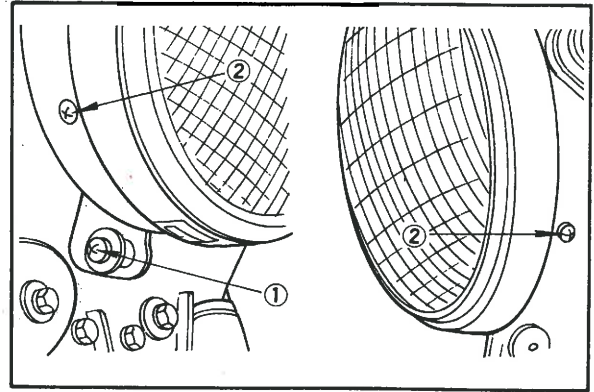

1. Holding screw
2. Anchor screw

Install the right footrest assembly using two spring washers (s-7), two plain washers (s-6) and two crown nuts (s-8).

Tightening torque:

37.5 ~ 52.5 ft-lb (5.0 ~ 7.0 m-kp)

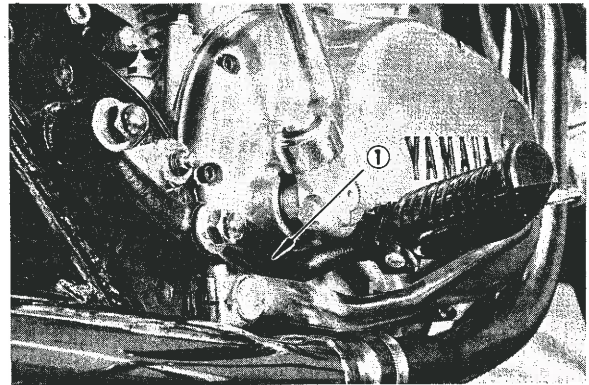

1. Right footrest

Taillight assembly installation

1. Install the two rubber dampers (r-15, r-16) contained in the vinyl bag on the tail/stoplight bracket.

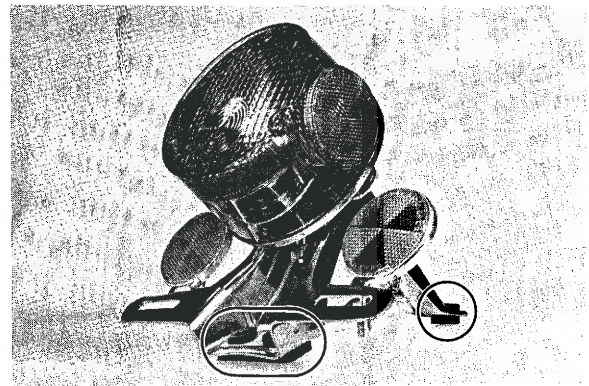

2. Connect the taillight assembly lead wire to the wire harness. (The wires of identical color should be connected.)

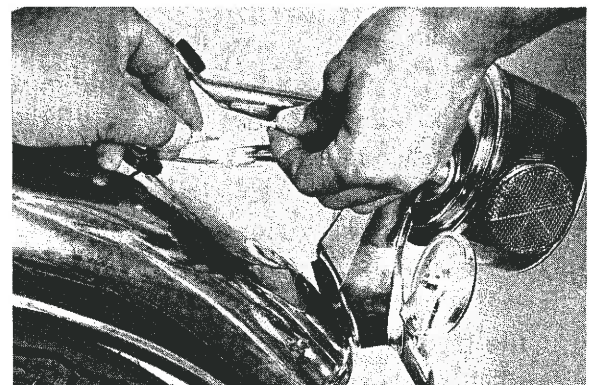

3. Using the bolt (r-17), washer with rim (r-18), fender mounting collar (r-19), spring washer (r-13) and nut (r-14) contained in the vinyl bag, secure the front part of the tail/stoptlight bracket to the rear fender.
4. Using the shoulder bolts (r-11), plain washers (r-12), spring washers (r-13) and nuts (r-14) contained in the vinyl bag, secure the rear part of the tail/stoptlight bracket to the fender.

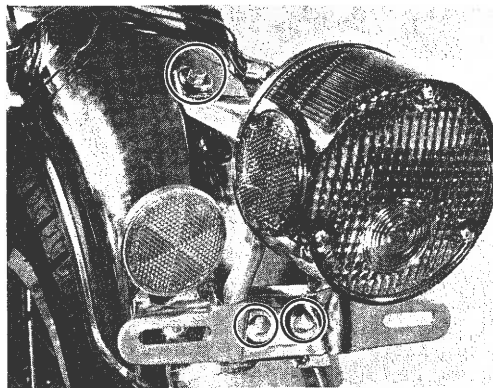

Secure the seat using the clip (s-2), clevis pins (s-1), bolt (s-5), spring washer (s-4) and stopper (s-3) as shown in the photo.

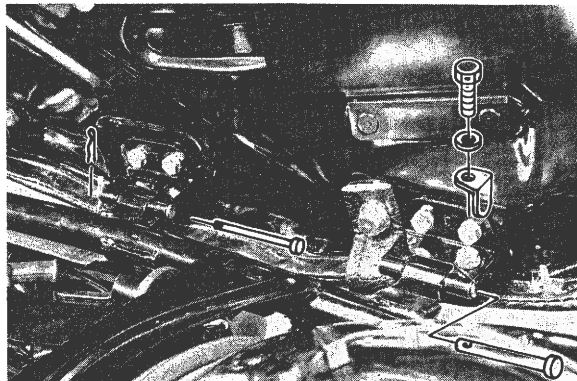

Remove the left side cover and insert the tool assembly (l) in the tool box. Install the left side cover.

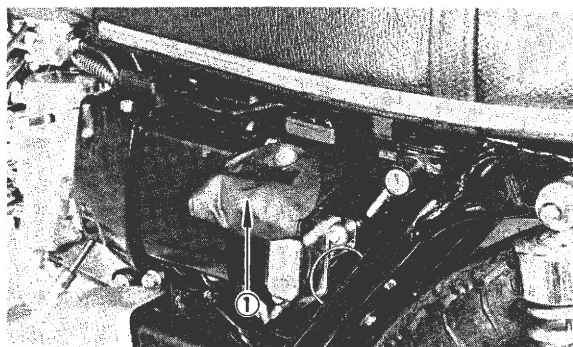

1. Tool kit

Battery

1. When filled with diluted sulfuric acid electrolyte, this battery can be put into use immediately. That is, it is a dry-charged battery. It is advisable, however, that the battery be charged as much as possible before using for the first time for maximum performance. This initial charge will prolong the life of the battery.
Charging current: 1.4A.
Charging hours: 10 hrs.

2. How to prepare diluted sulfuric acid
The diluted sulfuric acid can be prepared by adding sulfuric acid to distilled water at a specific mixing ratio.

Specific gravity at 20°C	Ratio of distilled water to sulfuric acid
1.25	3.4
1.26	3.2
1.27	3.0
1.28	2.8
1.29	2.7
1.30	2.6

Pour distilled water into a glass container, and add sulfuric acid while stirring with a glass stick. Adding the acid will generate heat, and therefore, care should be taken so that heat does not rise excessively.

CAUTION: _____
Never attempt to add distilled water to sulfuric acid.

3. Filling the battery with diluted sulfuric acid
- 1) Remove all filler caps from the battery, and remove the breather pipe cap at the same time.
 - 2) Cool the diluted sulfuric acid down to below 30°C (86°F).
 - 3) Pour diluted sulfuric acid into each cell little by little up to the upper level line, and leave it for a while. When the battery fluid permeates the plates and separators, the fluid level begins to lower. Add diluted sulfuric acid again.
 - 4) Charge the battery as required, and measure the specific gravity of the fluid.
 - 5) Install the filler caps, and thoroughly wipe off the fluid around the filler caps.

Battery installation

1. Make sure the main switch is turned off, and install the battery in the battery box. (Secure the battery with a band.) Connect the positive lead wire first, and then connect the negative lead wire.

NOTE: _____

After connecting the positive lead wire, be sure to place the rubber cover to prevent shorting.

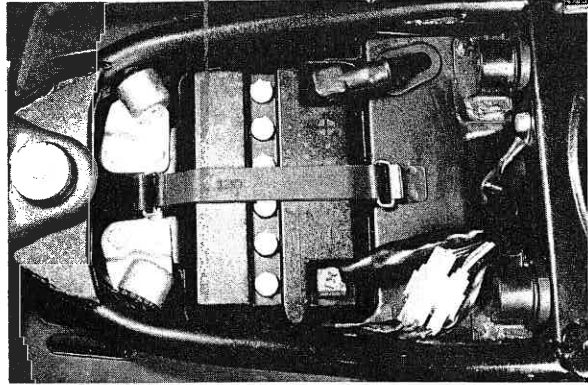

2. The breather pipe should be connected as illustrated.

NOTE: _____

Route the breather pipe outlet down and away from any part of the machine.

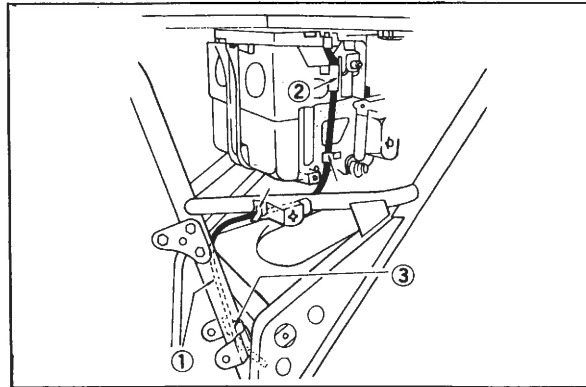

1. Right side
2. Pass through clamp 1. 2. 3.
3. Pass through clear space between bracket and engine

INSPECTIONS AND ADJUSTMENTS

Inspections

After all packed parts are installed, check to see that all these parts and other parts (mounted or installed at the Yamaha factory) are correctly mounted or installed, or tightened to specification. This check-up should be started with the front of the machine.

Item	
Front wheel spokes Tension
Front wheel rim Hopping, deflection
Front wheel tire Tire pressure
Front wheel axle nut Cotter pin, tightening torque
Front wheel axle holder locknuts Tightening torque
Disc brake caliper assembly lock bolts Tightening torque
Front fork pinch bolts Tightening torque
Steering head locknut Tightening torque
Handlebar holders Tightening torque
Clutch lever holder Tightening torque
Brake lever holder Tightening torque
Front flasher lights Mounting, wiring
Disk brake master cylinder Mounting, brake fluid level, operation
Throttle housing Position, operation, tightness
Engine mounting bolt Tightening torque
Carburetor joint(s) Tightness
Footrests Position, tightening torque
Change pedal Position, looseness, operation
Brake pedal Position, looseness, operation
Seat Mounting, clevis pin, clips
Fuel tank Mounting
Fuel pipe Connection
Battery Mounting, fluid level, wiring
Rear fender Mounting
Taillight Mounting, wiring
Rear flasher lights Mounting, wiring
Rear shock absorber Mounting, tightening torque
Rear swing arm pivot shaft Tightening torque
Rear axle nut Cotter pin, tightening torque
Chain puller Locknut
Rear wheel Spoke tension
Rear wheel rim Hopping, deflection
Rear wheel tire Tire pressure
Engine/Transmission oil Oil level

Adjustments

NOTE:

This section deals with the main points only.
For details, refer to the service manual for
this model.

Front brake adjustment

The front brake can be adjusted by simply adjusting the distance that the brake lever can travel since the piston in the wheel cylinder moves forward as the brake pad wears out, automatically adjusting the clearance between the brake pad and the brake disc.

1. Loosen the adjust screw locknut at the brake lever.
2. Turn the screw so that the brake lever trip moves 0.5 ~ 1.0 in (13 ~ 25 mm).
3. After adjusting, tighten the locknut.

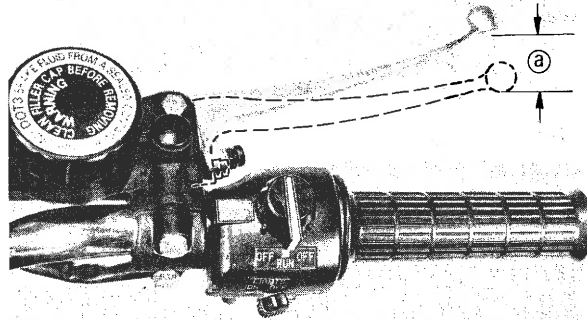

a: 0.5 ~ 1.0 in (13 ~ 25 mm)

Clutch wire adjustment

Loosen the clutch wire adjuster locknut at the clutch lever, and adjust the clutch wire by turning the wire adjuster.

Turning the adjuster clockwise (the adjuster is tightened) increases clutch wire play, while turning counterclockwise decreases the play. The play should be 1/16 ~ 1/8 in (2 ~ 3 mm) at the position shown in the figure.

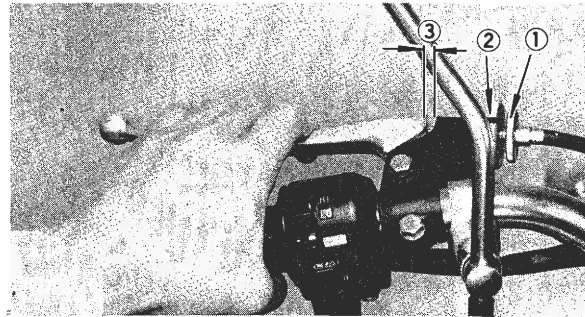

1. Adjusting bolt
2. Locknut
3. 1/16 ~ 1/8 in (2 ~ 3 mm)

Rear brake pedal adjustment

Rear brake pedal play can be adjusted by turning the adjusting nut on the rear end of the brake rod.

Turning clockwise (tightening) decreases play.

Turning counterclockwise (loosening) increases play.

Standard value:

- 0.8 ~ 1.1 in (20 ~ 30 mm) m
at the brake pedal

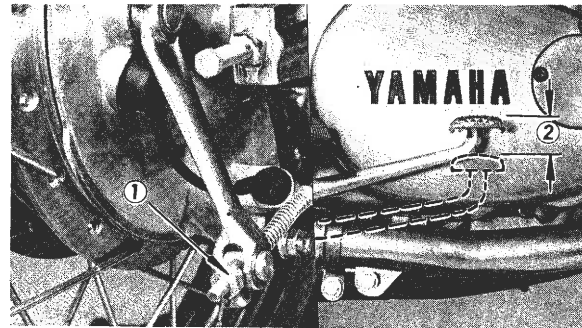

1. Adjust nut
2. 0.8 ~ 1.1 in (20 ~ 30 mm)

Torque specification

The following torque specifications must be adhered to on every machine. Tightening torque, on multi-secured components, several studs should be in gradual stages and in a pattern that will avoid warpage to the item being secured.

Torque settings are for dry, clean threads. Torquing should always be done to the nut, never the bolt head.

NOTE: _____

Certain items with other than standard thread pitches may require differing torque. Consult the model Service Manual or distributor if a question arises.

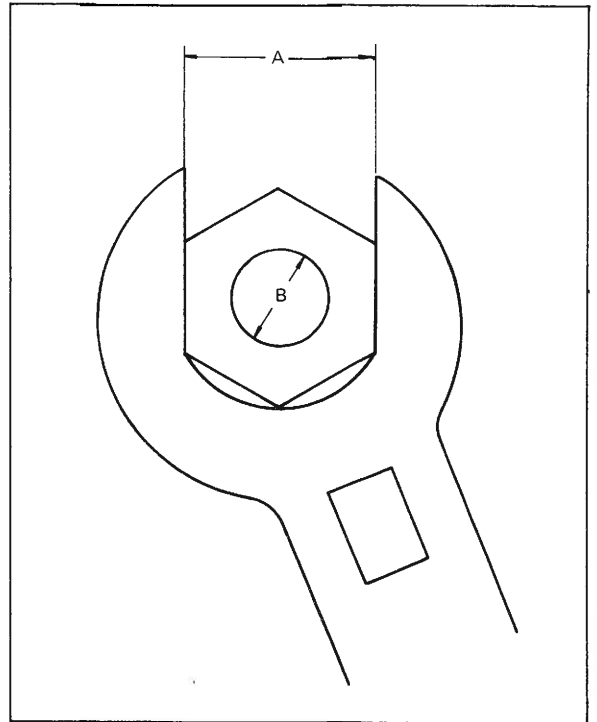

A (NUT)	B (BOLT)	TORQUE SPECIFICATIONS		
		m-kg	ft-lb	in-lb
10 mm	6 mm	1.0	7.2	85
12 mm	8 mm	2.0	15	175
14 mm	10 mm	3.5 ~ 4.0	25 ~ 29	300 ~ 350
17 mm	12 mm	4.0 ~ 4.5	29 ~ 33	350 ~ 400
19 mm	14 mm	4.5 ~ 5.0	33 ~ 36	400 ~ 440
22 mm	16 mm	5.6 ~ 6.5	41 ~ 49	480 ~ 570
24 mm	18 mm	5.8 ~ 7.0	42 ~ 50	504 ~ 600
27 mm	20 mm	7.0 ~ 8.3	50 ~ 60	600 ~ 700

CABLE ROUTING

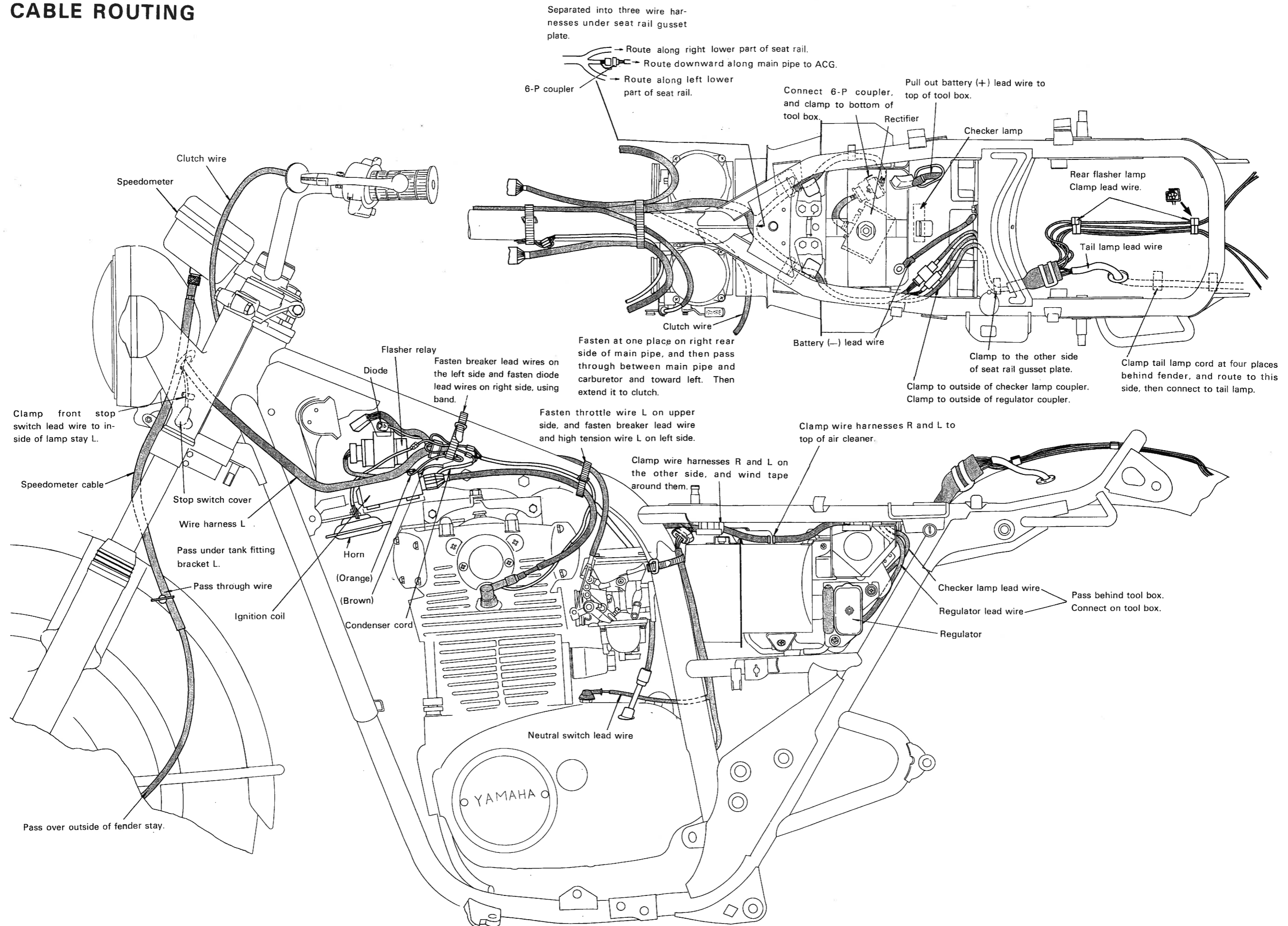

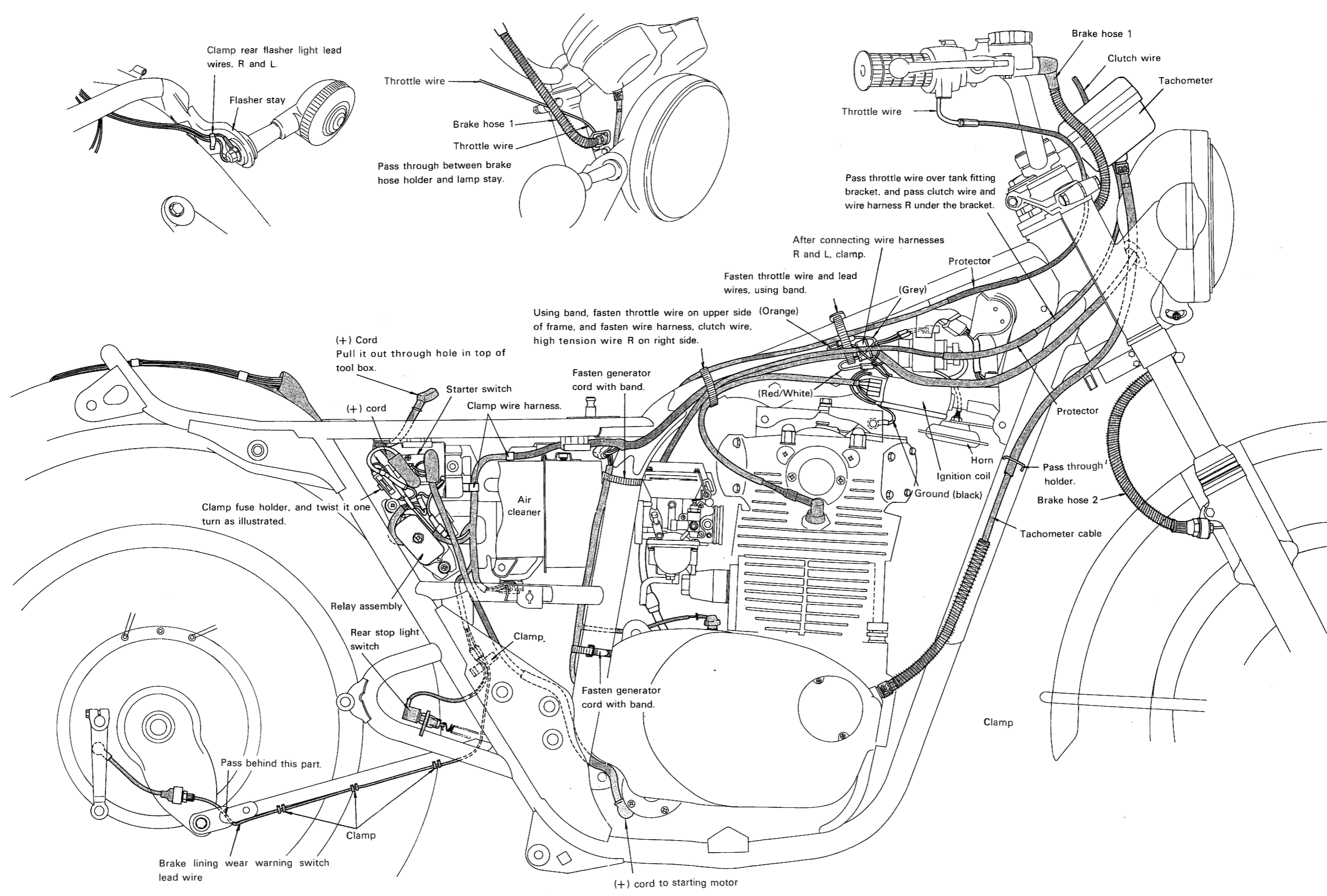

Clamp rear flasher light lead wires, R and L.

Flasher stay

Throttle wire

Brake hose 1

Throttle wire

Pass through between brake hose holder and lamp stay.

Brake hose 1

Clutch wire

Tachometer

Throttle wire

Pass throttle wire over tank fitting bracket, and pass clutch wire and wire harness R under the bracket.

After connecting wire harnesses R and L, clamp.

Fasten throttle wire and lead wires, using band.

(Grey)

Using band, fasten throttle wire on upper side (Orange) of frame, and fasten wire harness, clutch wire, high tension wire R on right side.

(+) Cord
Pull it out through hole in top of tool box.

Starter switch

Clamp wire harness.

Fasten generator cord with band.

(Red/White)

Horn

Ignition coil

Ground (black)

Protector

Pass through holder.

Brake hose 2

Tachometer cable

Clamp fuse holder, and twist it one turn as illustrated.

Relay assembly

Rear stop light switch

Clamp.

Fasten generator cord with band.

Clamp

Pass behind this part.

Clamp

Brake lining wear warning switch lead wire

(+) cord to starting motor



SINCE 1887

YAMAHA MOTOR CO., LTD.

IWATA, JAPAN

PRINTED IN JAPAN
75 • 8 - 2.55 x 1 ©

LIT-11666-00-19