

YAMAHA

MOTORCYCLE

TX650A

ASSEMBLY MANUAL

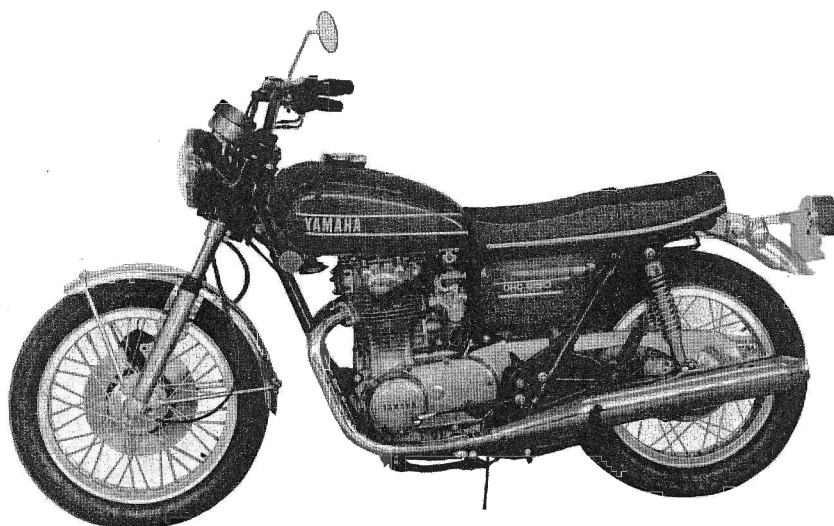

YAMAHA MOTOR CO., LTD.

NOTICE

This manual has been written by Yamaha Motor Company for use by Authorized Yamaha Dealers and their qualified mechanics. In light of this purpose it has been assumed that certain basic mechanical precepts and procedures inherent to our product are already known and understood by the reader. Without such basic knowledge, incorrect assembly of the machine could occur. This may render the machine unsafe.

The dealer is further cautioned to review the Service Manual for the machine being assembled in order to acquaint himself with the servicing procedures on the machine after assembly has been completed.

The Research and Service Departments of Yamaha are continually striving to further improve all models manufactured by the company. Modifications are therefore inevitable and changes in specifications or procedures mentioned within this manual will be forwarded to all Authorized Yamaha Dealers and will, where applicable, appear in future editions of this manual.

Should the dealer note a difference between the information in this manual and the actual model, he is advised to contact the U.S. Distributor, Yamaha International Corporation (Canada Distributor: Yamaha Motor Canada Ltd.), per established routine for clarification.

YAMAHA TX650A
ASSEMBLY MANUAL
1st Edition, January 1974
SERVICE DEPARTMENT
YAMAHA MOTOR CO., LTD.
IWATA, JAPAN
LIT-11664-47-00

A. TORQUE SPECIFICATIONS

The following torque specifications must be adhered to on every machine. Some items with several fasteners should be torqued down in a cross hatch pattern in successive stages until torque specification is reached. The method is similar to installing an automobile wheel and will avoid warping the component.

Torque settings are for dry, clean threads. Torquing should always be done to the nut, never to the bolt head.

Note:

Certain items with other than standard thread pitches may require differing torque. Consult the model Service Manual or distributor if a question arises.

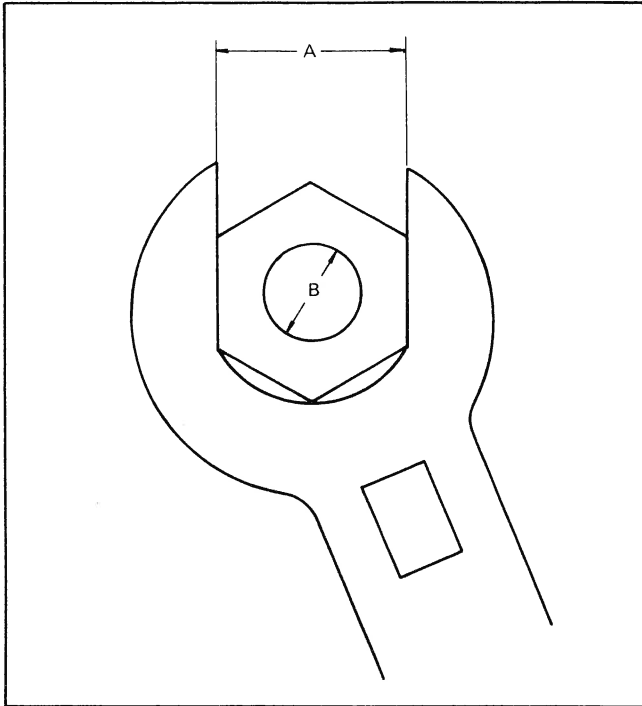

Fig. 1

Torque Specifications

A	B			
(Nut)	(Bolt)	m-kg.	ft-lbs.	in-lbs.
10 mm.	6 mm.	1.0	7.2	85
10 mm.	7 mm.	1.5	11	135
13 mm.	8 mm.	2.0	15	175
14 mm.				
17 mm.	10 mm.	3.5-4.0	20-29	300-350
19 mm.	12 mm.	4.0-4.5	29-33	350-400
22 mm.	14 mm.	4.5-5.0	33-36	400-440
26 mm.	17 mm.	5.8-7.0	42-50	500-600
27 mm.	18 mm.	5.8-7.0	42-50	500-600
30 mm.	20 mm.	7.0-8.3	50-60	600-700
SPARK PLUGS		2.7-2.9	19-21	230-250

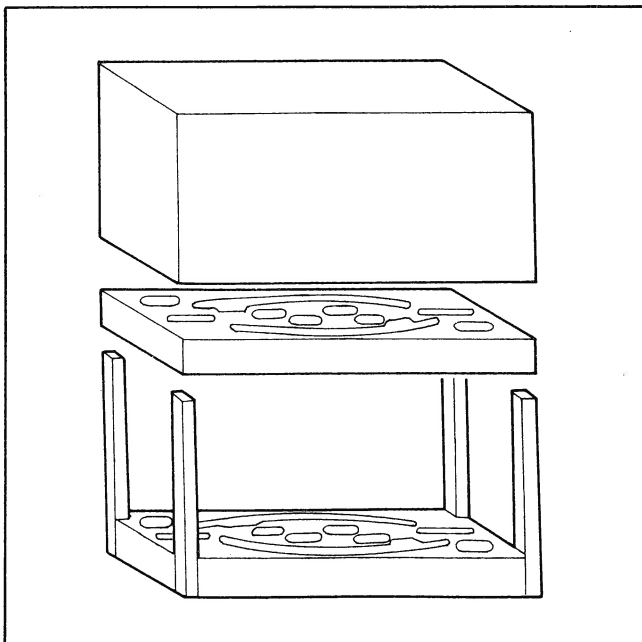

Fig. 2

B. UNPACKING

1. The TX650A is put in a cardboard crate. To unpack, cut steel bands wound around the cardboard crate using a cutter, and then take it out.

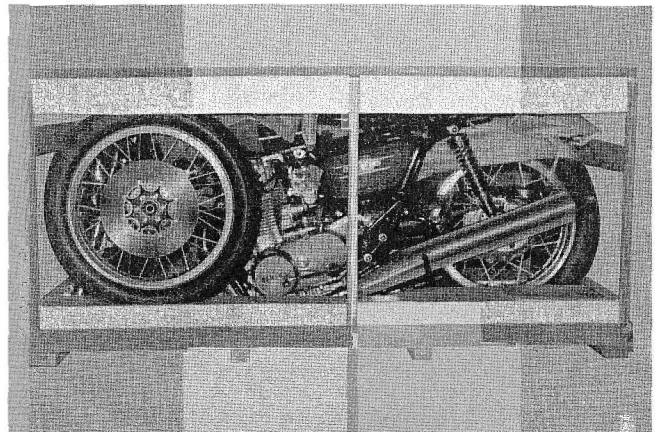

Fig. 3

2. Check the parts contained in the foam styrol case for quantity and damage. If any parts are found damaged, replace.

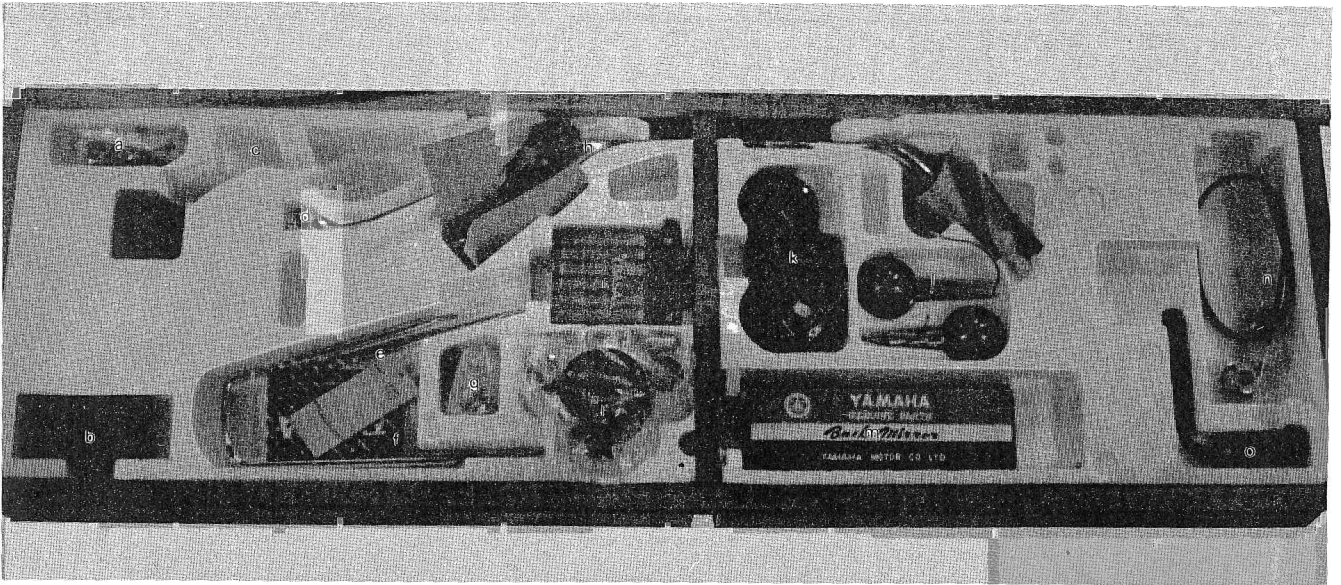
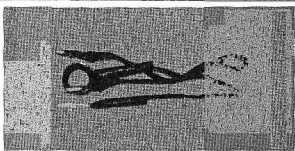

Fig. 4

C. CHECK LIST

Setting Position	Part Name	Q'ty
a	Vinyl bag (Bolts, nuts, etc.)	1
b	Service tools	1 set
c	Disc (Master cylinder)	1
d	Brake pedal	1
e	Front fender stay	2
f	Owner's Manual	1
g	Vinyl bag (Bolts, nuts, etc.)	1
h	Handlebar assembly	1
i	Battery	1
j	Tail/Stop lamp assembly	1
k	Meter panel assembly	1
l	Front flasher lamp assembly	1
m	Back mirror assembly	1
n-1	Speedometer cable assembly	1
n-2	Front wheel shaft collar	1
o	Right foot rest assembly	1

1. Details of Parts in the setting position "a"

No.	Photo	Part Name	Q'ty
a-1		Negative lead wire	2



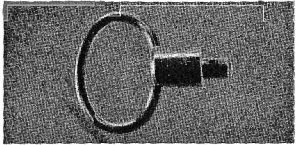
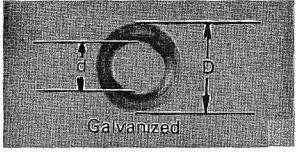
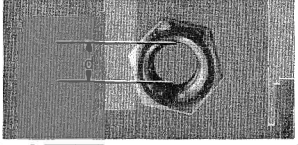
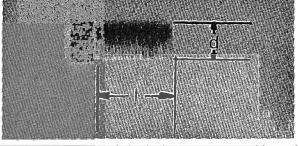
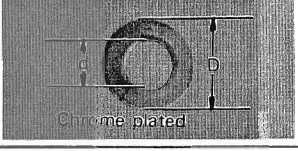
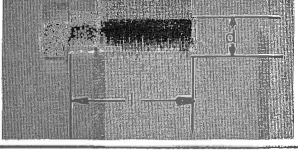
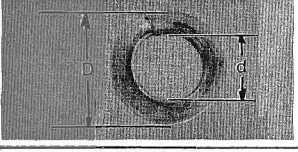
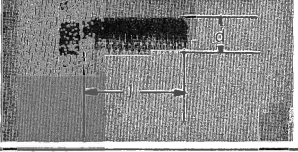
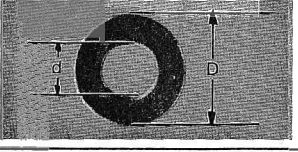
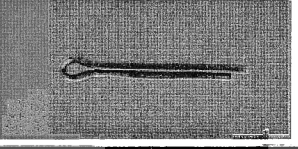

Vinyl bag (1)

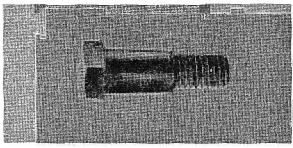
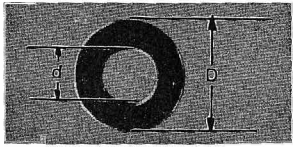
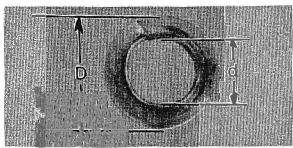
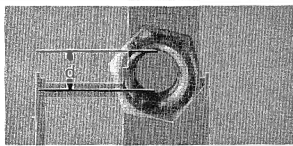
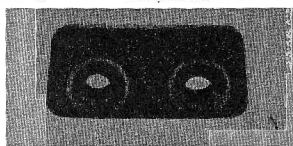
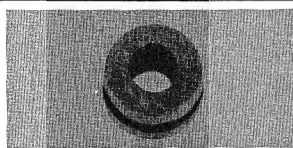
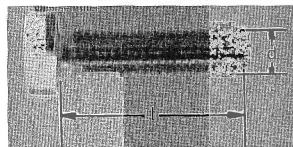
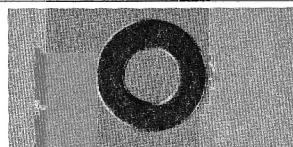
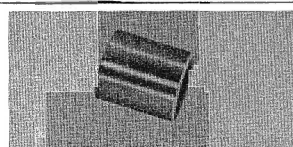
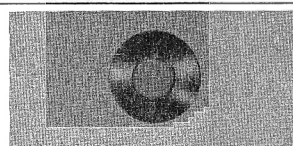
No.	Photo	Part Name	Q'ty
a-2		Wire holder	1
a-3	 <p>Galvanized</p>	Spring washer (d=6.2 mm. D=12.3 mm. t=1.5 mm. Galvanized)	1
a-4		Nut (d=6 mm.)	1
a-5		Bolt (d=6 mm. l=12 mm.)	6
a-6	 <p>Chrome plated</p>	Spring washer (d=6.2 mm. D=12.3 mm. t=1.5 mm. Chrome-plated)	10
a-7		Bolt (d=8 mm. l=20 mm.)	4
a-8		Spring washer (d=8.2 mm. D=15.4 mm. t=2.0 mm.)	4
a-9		Bolt (d=6 mm. l=18 mm.)	4
a-10		Plain washer (d=6.5 mm. D=13 mm. t=1 mm.)	4
a-11		Cotter pin	1

Vinyl bag (2)

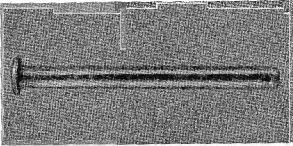
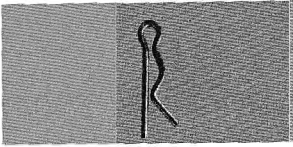
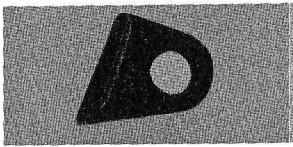
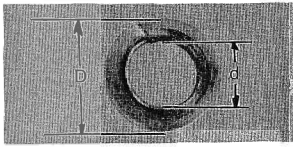
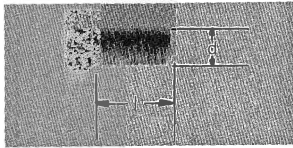
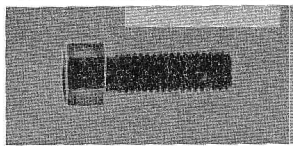
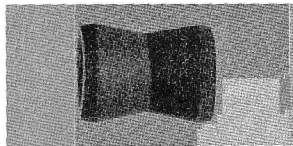
No.	Photo	Part Name	Q'ty
a-12		Shoulder Bolt	2
a-13		Plain washer (d=8.5 mm. D=18 mm. t=1.6 mm.)	2
a-14		Spring washer (d=6.2 mm. D=12.3 mm. t=1.5 mm.)	3
a-15		Nut (d=6 mm.)	3
a-16		Damper rubber	1
a-17		Damper rubber	1
a-18		Bolt (d=6 mm. l=25 mm.)	1
a-19		Washer with cover	1
a-20		Fender mount collar	1
a-21		Bolt cap	6

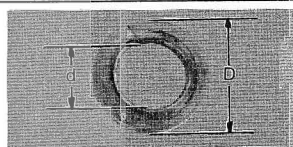
2. Details of parts in the setting position "g"

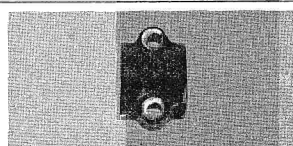
No.	Photo	Part Name	Q'ty
g-1		Clevis pin	2
g-2		Clip	2
g-3		Stopper	1
g-4		Spring washer (d=6.2 mm. D=12.3 mm. t=1.5 mm.)	1
g-5		Bolt (d=6 mm. l=8 mm.)	1
g-6		Internal hexagon socket head bolt	2
g-7		Damper rubber	1
g-8		Plain washer (d=10 mm. D=25 mm. t=2.0 mm.)	2
g-9		Spring washer (d=10.3 mm. D=18.5 mm. t=2.0 mm.)	2
g-10		Crown nut	2
g-11		Lever holder	1

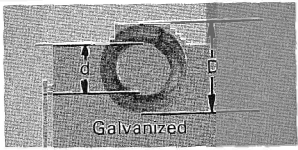
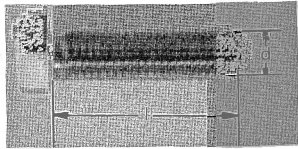
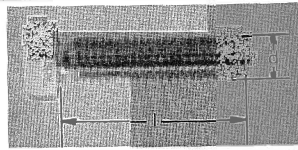
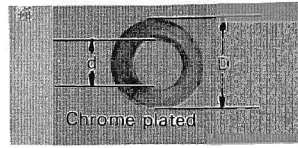
No.	Photo	Part Name	Q'ty
g-12		Spring washer (d=6.2 mm. D=12.3 mm. t=1.5 mm. Galvanized)	2
g-13		Bolt (d=6 mm. l=25 mm. Galvanized)	2
g-14		Bolt (d=6 mm. l=25 mm. Chrome-plated)	1
g-15		Spring washer (d=6.2 mm. D=12.3 mm. t=1.5 mm. Chrome-plated)	1

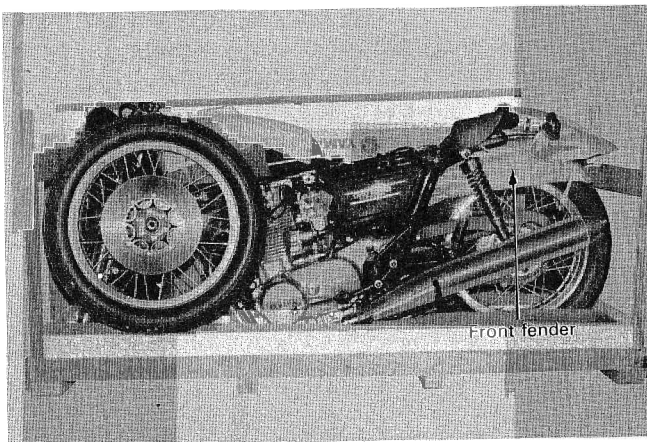

Fig. 5

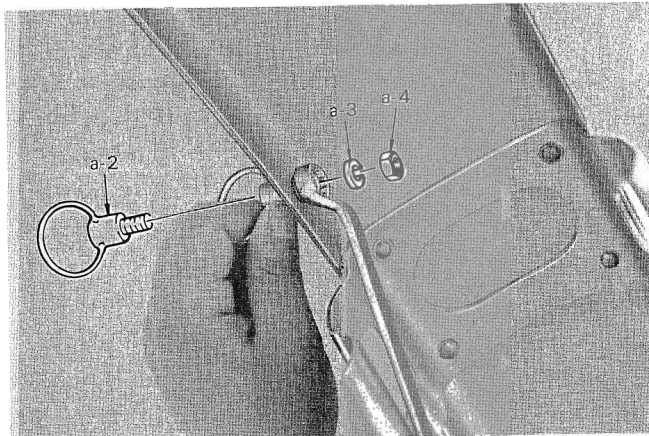

Fig. 6

D. SET-UP PROCEDURES

1. Take out the front fender which is placed between the rear wheel and the rear fender, and take out the seat and front wheel which are placed on each side of the front forks. (Fig. 5)
2.
 - a) Hold the steering handlebars (located on the left rear side of the motorcycle) and the frame, and lift up the motorcycle. Then take out the rear wheel from the lower foam styrol case, and erect the main stand.
 - b) Place a suitable support under the engine in front of the main stand. This will keep the front of the machine elevated while the front fender and front wheel are installed.
3. Install the wire holder (a-2) using spring washer (a-3) and nut (a-4). (Figs. 6 and 7)

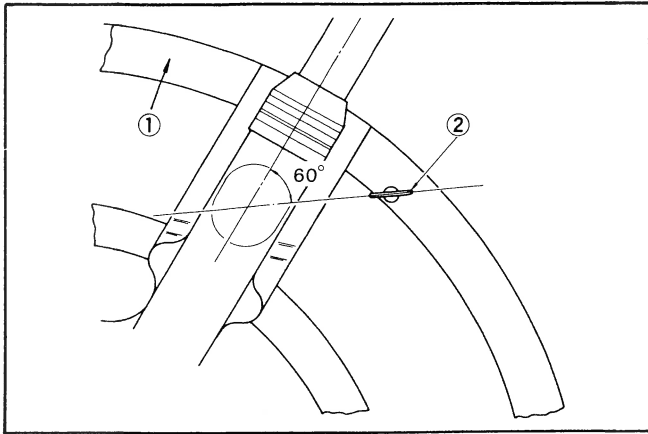

Fig. 7

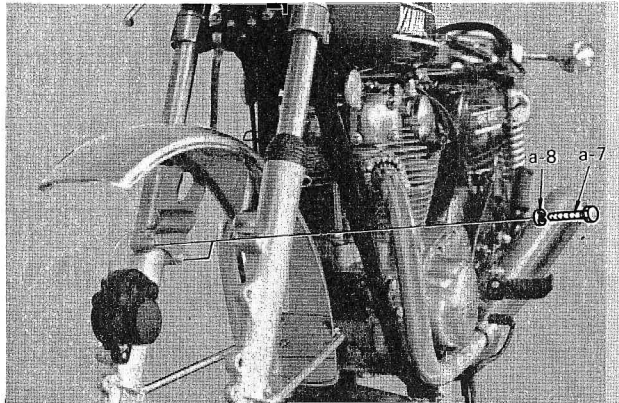

Fig. 8

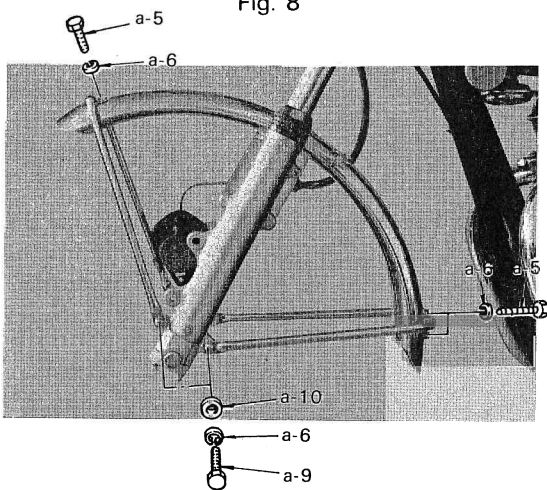

Fig. 9

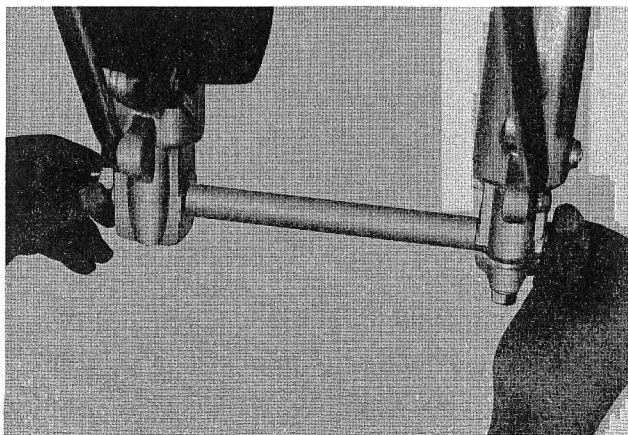

Fig. 10

1. Front fender
2. Wire holder

4. Insert the front fender between the front forks from the rear, and secure the front fender using 8 mm. bolts (a-7) and spring washers (a-8), four each. (Fig. 8)

Tightening torque:
70 — 110 in-lbs. (0.8 — 1.3 m-kgs.)

5. Install the two fender stays (e) on the front fender and the front forks. (Fig. 9)
 - a) Use six 6 x 12-bolts (a-5) and six spring washers (a-6) contained in the vinyl bag (1) on the fender side.
 - b) Use four 6 x 18-bolts (a-9), four spring washers (a-6), and four plain washers (a-10) contained in the vinyl bag (1) for the front forks side.

Tightening torque:
60 — 85 in-lbs. (0.6 — 0.9 m-kgs.)

6. Loosen the two nuts securing the axle holder (left side front fork leg). Next, remove the wheel shaft nut, plain washer, and pull out the wheel shaft. (Fig. 10)

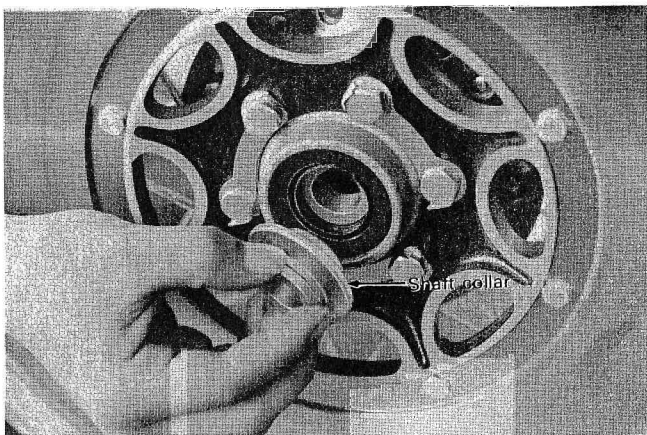

Fig. 11

7. Install the shaft collar (n-2) on the wheel shaft on the front wheel disc side (right side). (Fig. 11)

Note:

To avoid damaging the oil seal lip, be sure to grease the shaft collar. (Use light-weight lithium soap base grease.) If the shaft collar is found dirty, it should be cleaned with a cloth.

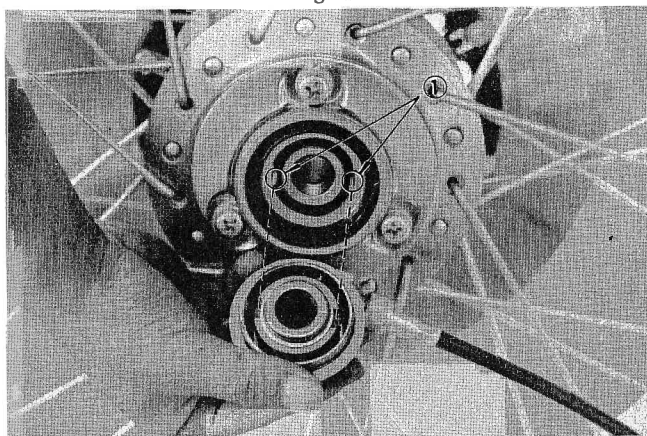

Fig. 12

8. Install the speedometer cable assembly (n-1) on the left side of the front wheel. (Fig. 12)

- a) Lightly grease the lips of the front wheel oil seals.
- b) Sparingly grease the teeth of the speedometer drive and driven gears.
Use light-weight lithium soap base grease.

Note:

Make sure that the two projections of the meter clutch inside the wheel hub are perfectly meshed with the two recesses in the meter gear unit of the speedometer cable assembly.

1. Projections

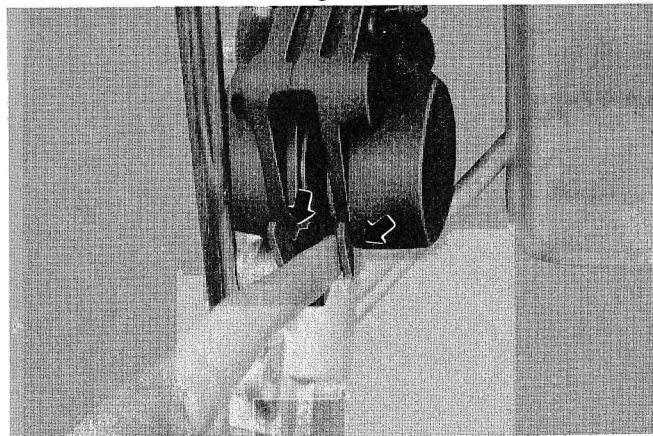

Fig. 13

9. The two pads in the disc brake caliper assembly should be kept forced into their seats. (Fig. 13)

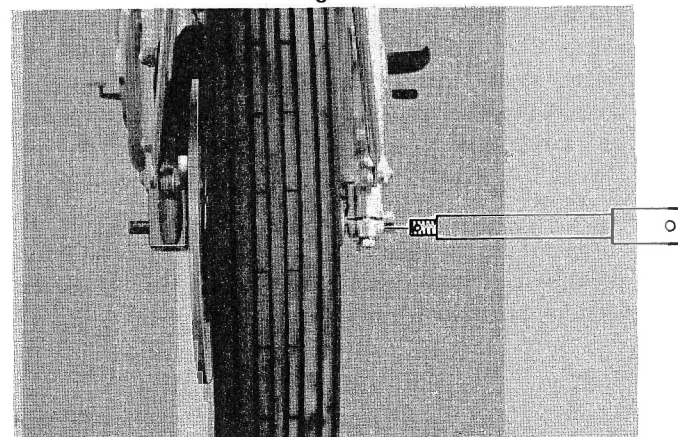

Fig. 14

10. Install the front wheel in the front forks. (Fig. 14)

- a) Make sure the caliper pads are pushed apart, and then put the front wheel disc into the caliper assembly from the front side of the motorcycle.
- b) Hold down the shaft collar on the right side of the front wheel and the meter gear unit on the left side, and set the front wheel in place.
- c) Insert the wheel shaft.

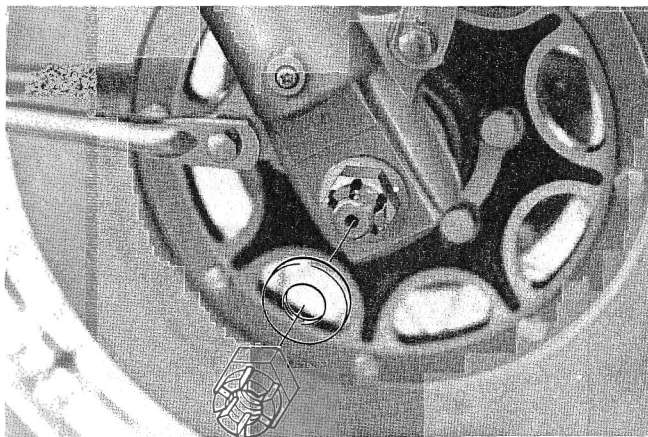

Fig. 15

11. Install the plain washer and wheel shaft nut on the wheel shaft, and tighten the nut with specified torque. (Fig. 15)

Tightening torque:

53.5 — 75.0 ft-lbs. (7.0 — 10.0 m-kgs.)

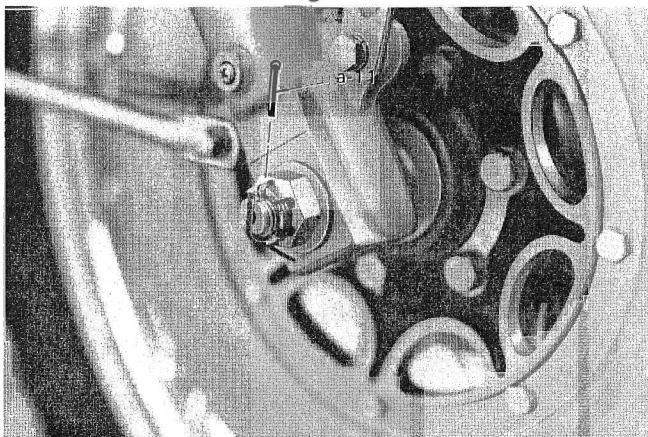

Fig. 16

12. Lock the wheel shaft nut with the cotter pin (a-11) contained in vinyl bag (1). (Fig. 16)

Note:

The cotter pin should be installed with the open ends pointing down, prior to bending the ends apart.

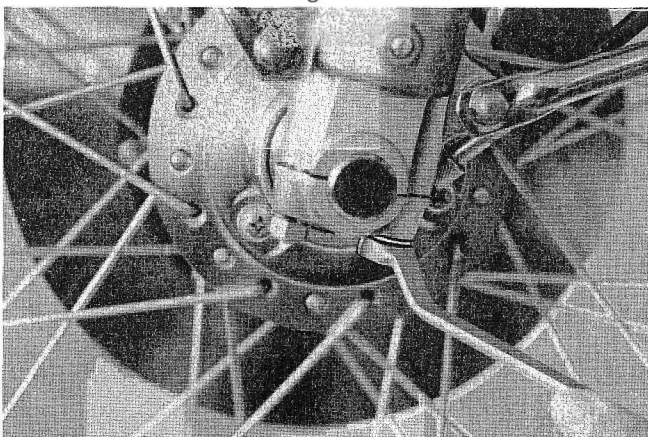

Fig. 17

13. Tighten the two axle holder nuts with specified torque. (Fig. 17)

Tightening torque:

70 — 110 in-lbs. (0.8 — 1.3 m-kgs.)

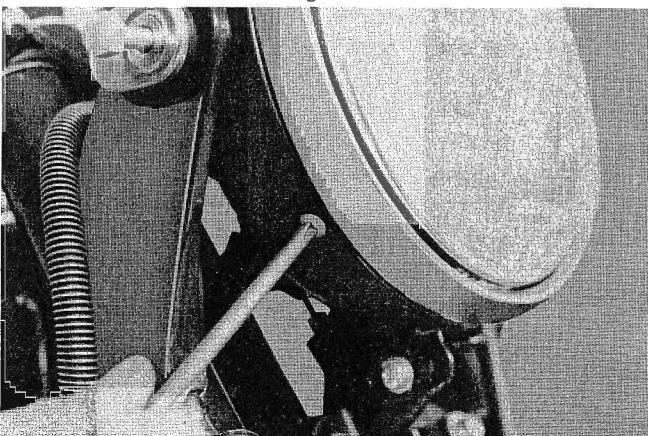

Fig. 18

14. Remove the two Phillips-head anchor screws, one each, from the lower right and left parts of the head lamp shell. Insert a slotted-head screwdriver between the shell and the lens assembly mounting ring on the bottom of the head lamp shell, and pry out the lens assembly. (Fig. 18)

Note:

Care should be taken not to scratch the head lamp shell with the slotted-head screwdriver. Also be careful not to lose any screw.

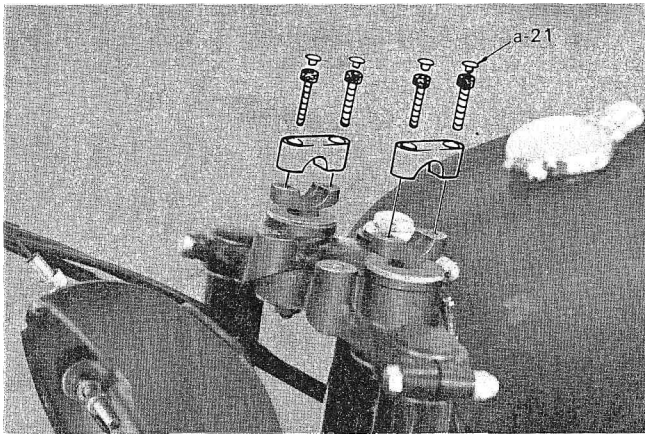

Fig. 19

15. Remove the four hexagon socket head bolts, and remove the two handle upper holders. (Fig. 19)

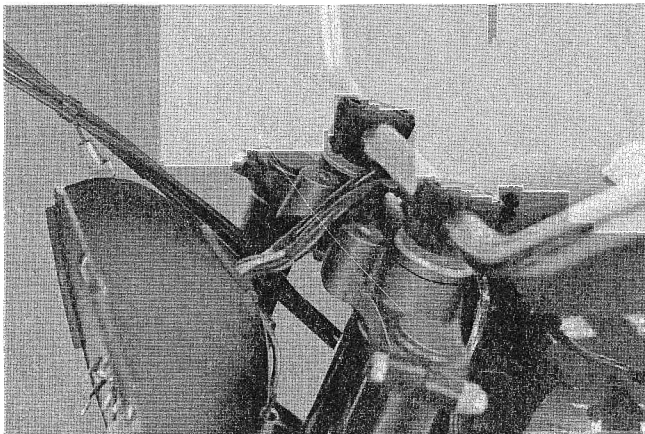

Fig. 20

16. First, thread the handle wires through the head lamp body grommet, and install the handlebar assembly (h) using the two handle upper holders, four hexagon socket head bolts (removed in procedure 15) and four bolt caps (a-21). (Fig. 20)

Tightening torque:

160 — 230 in-lbs. (1.8 — 2.5 m-kgs.)

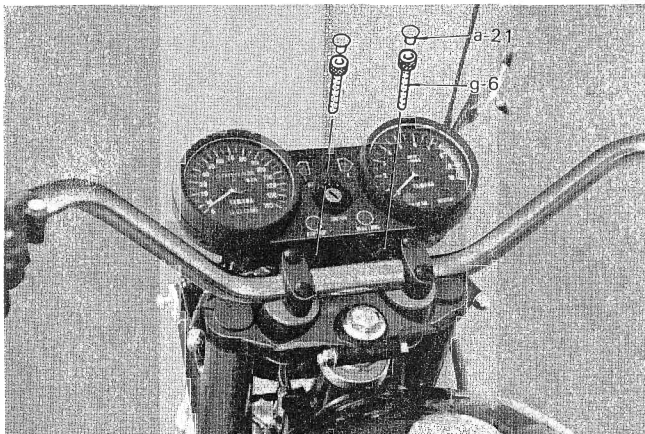

Fig. 21

17. Install the meter panel assembly (k) on the handle crown using the two hexagon socket head bolts (g-6) and bolts caps (a-21) contained in the vinyl bag. Before securing the meter panel assembly, all wires should be threaded through the head lamp body grommet. (Fig. 21)

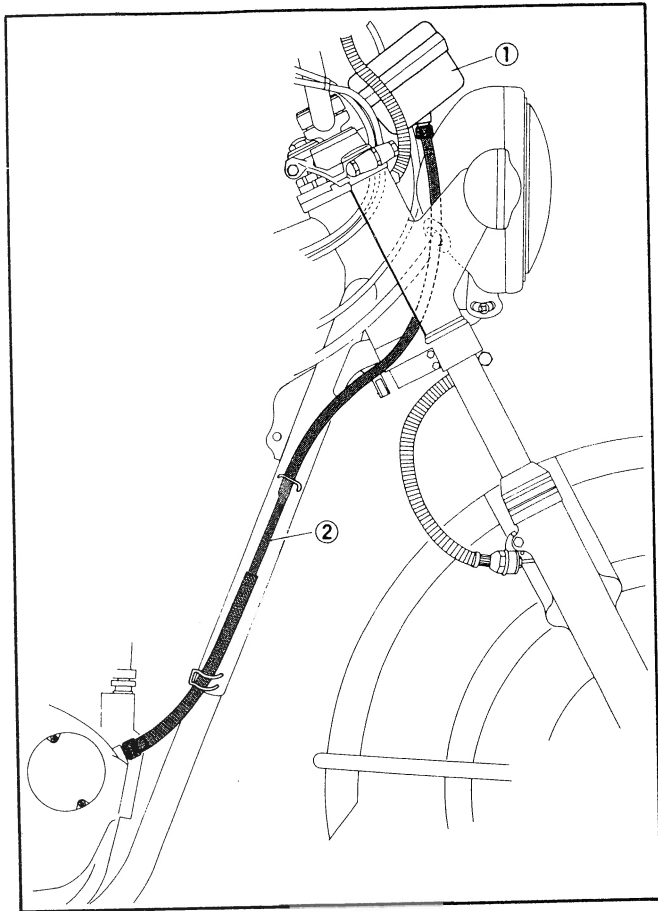

Fig. 22

18. Connect the tachometer cable to the tachometer. For detailed cable routing, refer to illustration. (Fig. 22)

- 1. Tachometer
- 2. Tachometer cable

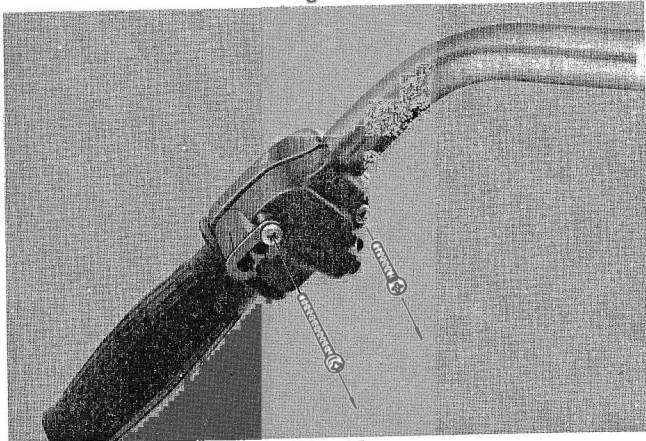

Fig. 23

19. Remove the two setting screws holding the right-hand handle switch assembly, and separate the switch assembly. (Fig. 23)

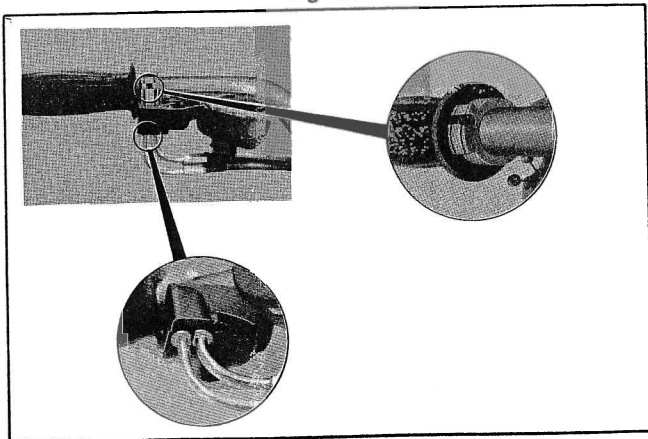

Fig. 24

20. Thread the two throttle wires through the two holes in the lower handle lever holder. Hook the throttle cable ends into their seats in the throttle guide housing. Then, grease the throttle cables and handle lever holder. Next, bolt the upper and lower handle lever holders together, and check the accelerator grip for smooth action. (Fig. 24)

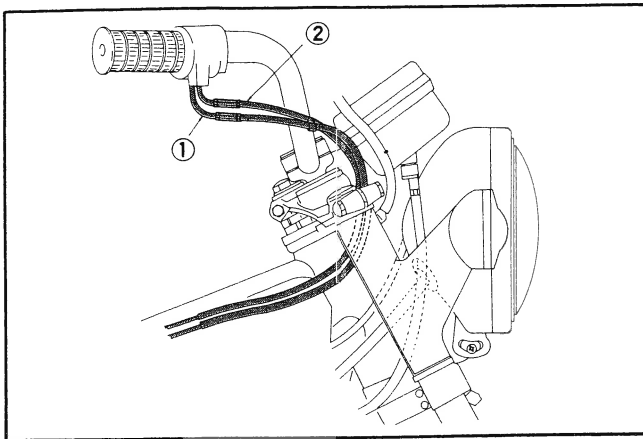

Fig. 25

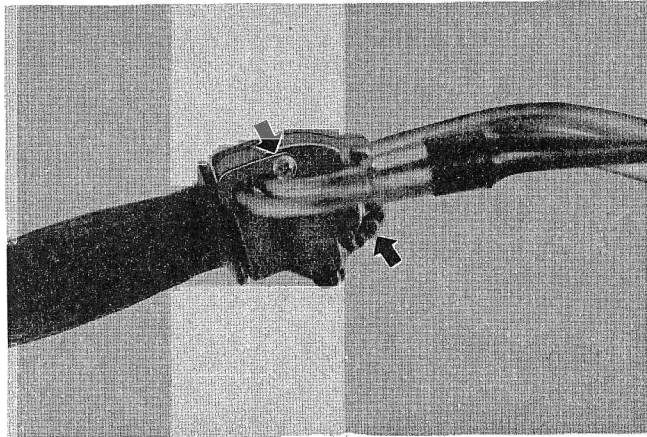

Fig. 26

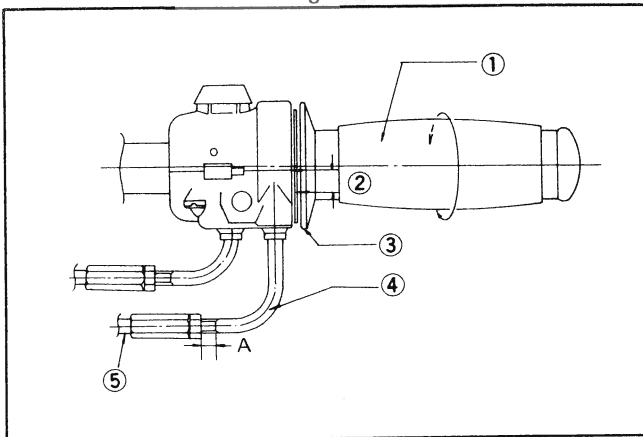

Fig. 27

USE LIGHT-WEIGHT LITHIUM SOAP BASE GREASE.

For detailed cable routing, refer to illustration. (Fig. 25)

1. To right side carburetor
2. To left side carburetor

21. Using the screws removed in procedure 19, assemble the upper and lower halves of the handle lever holder, and secure the assembly to the handle bar. (Fig. 26)

-IMPORTANT-

The play in turning direction of the throttle grip must be adjusted to prevent the throttle wire from slipping off the throttle wire holder.

Throttle wire adjustment (Fig. 27)

1. Check play in turning direction of throttle grip. The play must be in the range of 5 to 10 mm. at grip flange. (Measuring point is optional.)
2. If the play exceeds 10 mm., adjust with adjusting nut on throttle wire 2 side.
3. If adjustment is impossible with the adjusting nut (because distance "A" must be maintained more than 4 mm.), then use adjusting nut on throttle wire 1 side.

1. Throttle grip
2. Turning play 5 – 10 mm.
3. Grip flange
4. Throttle wire 2
5. Throttle wire 1

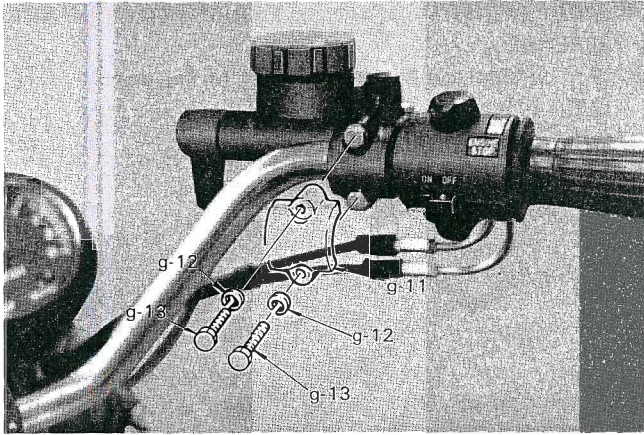

Fig. 28

22. Install the front brake master cylinder assembly using two bolts (g-13), two spring washers (g-12) and lever holder (g-11) contained in the vinyl bag. (Fig. 28)

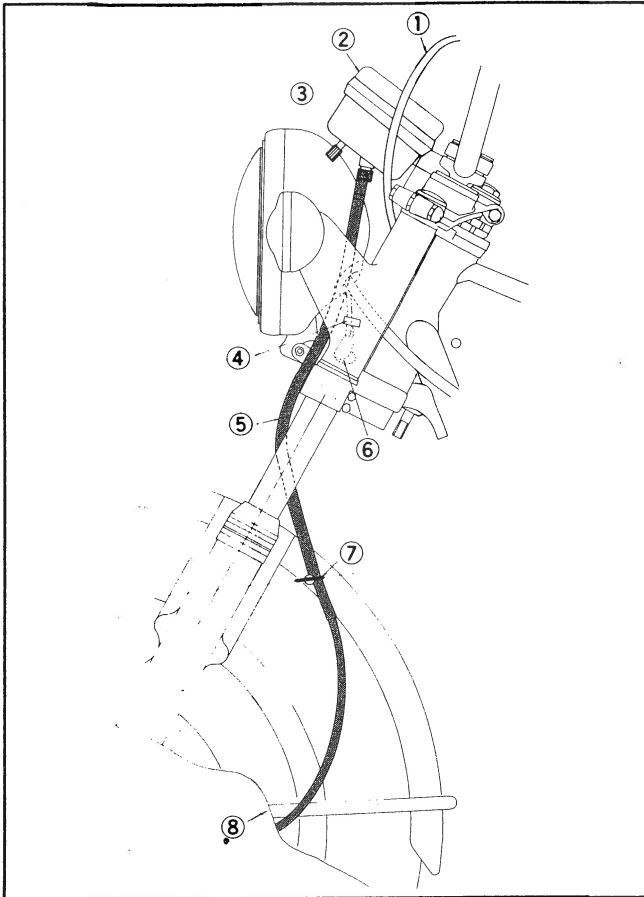

Fig. 29

23. Connect the speedometer cable to the speedometer. For detailed cable routing, refer to illustration. (Fig. 29)

1. Clutch wire
2. Speedometer
3. Speedometer (front)
4. Clamp the float stop switch inside the clamp stay
5. Speedometer cable
6. Cover stop switch
7. Pass through wire holder
8. Pass outside the fender stay

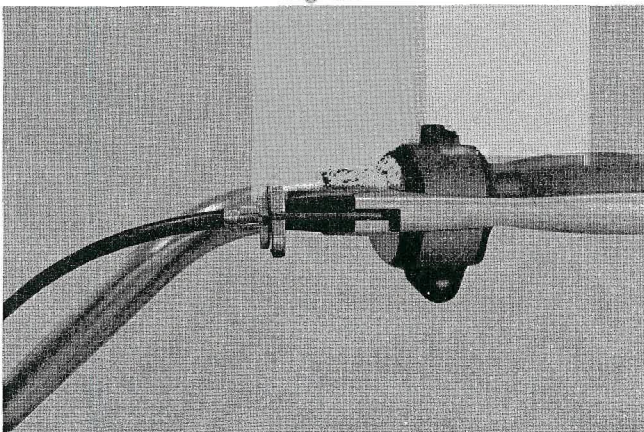

Fig. 30

24. Connect the clutch cable to the clutch lever (on the left part of the handlebars).
- a) Fully loosen the clutch lever lock nut, and screw in the adjusting bolt until it becomes tight so that the clutch lever lock nut slot is aligned with the adjusting bolt slot. Next, connect the clutch cable end to the clutch lever, and hook up the outer clutch cable to the lock nut. Then, fully pull in the clutch lever, and release it abruptly. At the same time, pull the outer clutch cable quickly. This makes easy the connection of the outer clutch cable to the adjusting bolt. (Fig. 30)

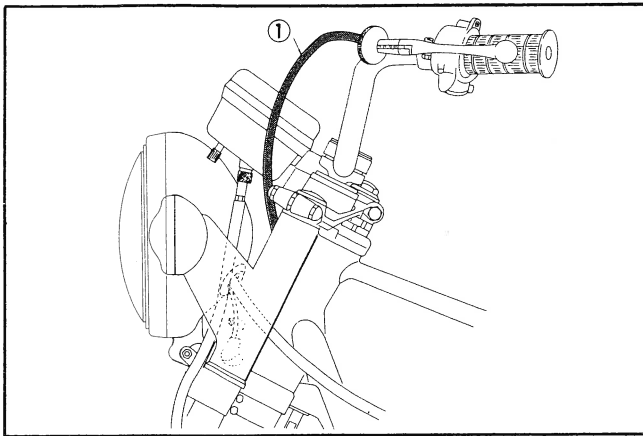

Fig. 31

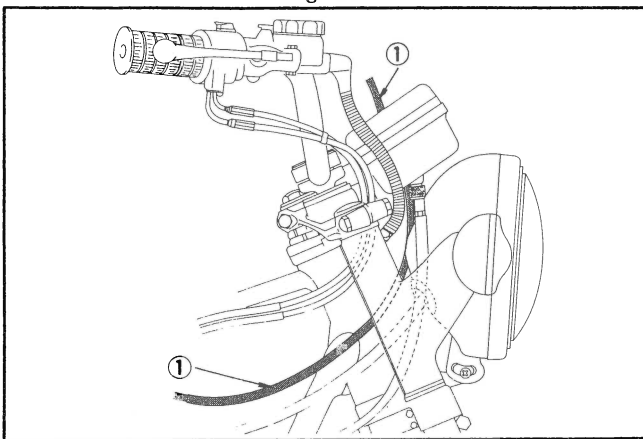

Fig. 32

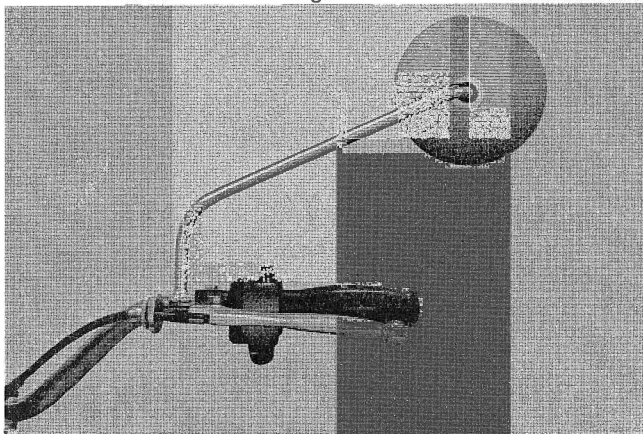

Fig. 33

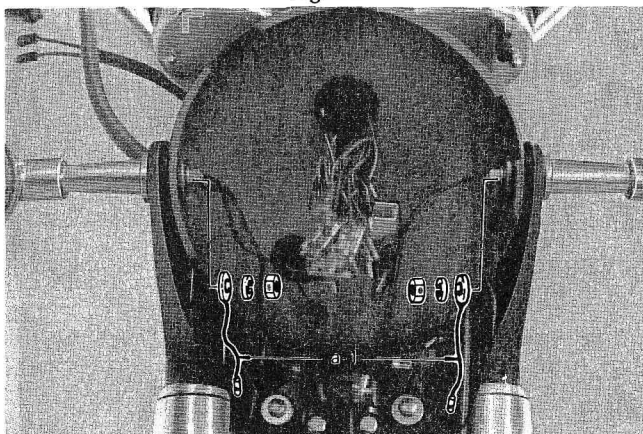

Fig. 34

For detailed cable routing, refer to illustration. (Figs. 31 and 32)

- b) Back out the cable length adjuster until the clutch lever has 1/16 — 1/8 in. (2 — 3 mm.) slack.
Tighten the adjuster lock nut.

1. Clutch cable

1. Clutch cable

25.

- a) Install the mirror assembly on the left side of the handlebars.
- b) Adjust for proper rear view. (Fig. 33)

26. Remove the bolts and nuts securing the headlamp shell and headlamp stays temporarily. The two bolts and not used.

27. Install the right and left flasher lamp assemblies and negative lead wires (a-1) using two spring washers and nuts which were used for temporary installation. (Fig. 34)

28. Connect lead wires inside the headlamp shell. Lead wires of the identical color should be connected. (Except #1, 2, 3 in illustration on the following page.)

WIRE CONNECTION IN HEADLAMP SHELL

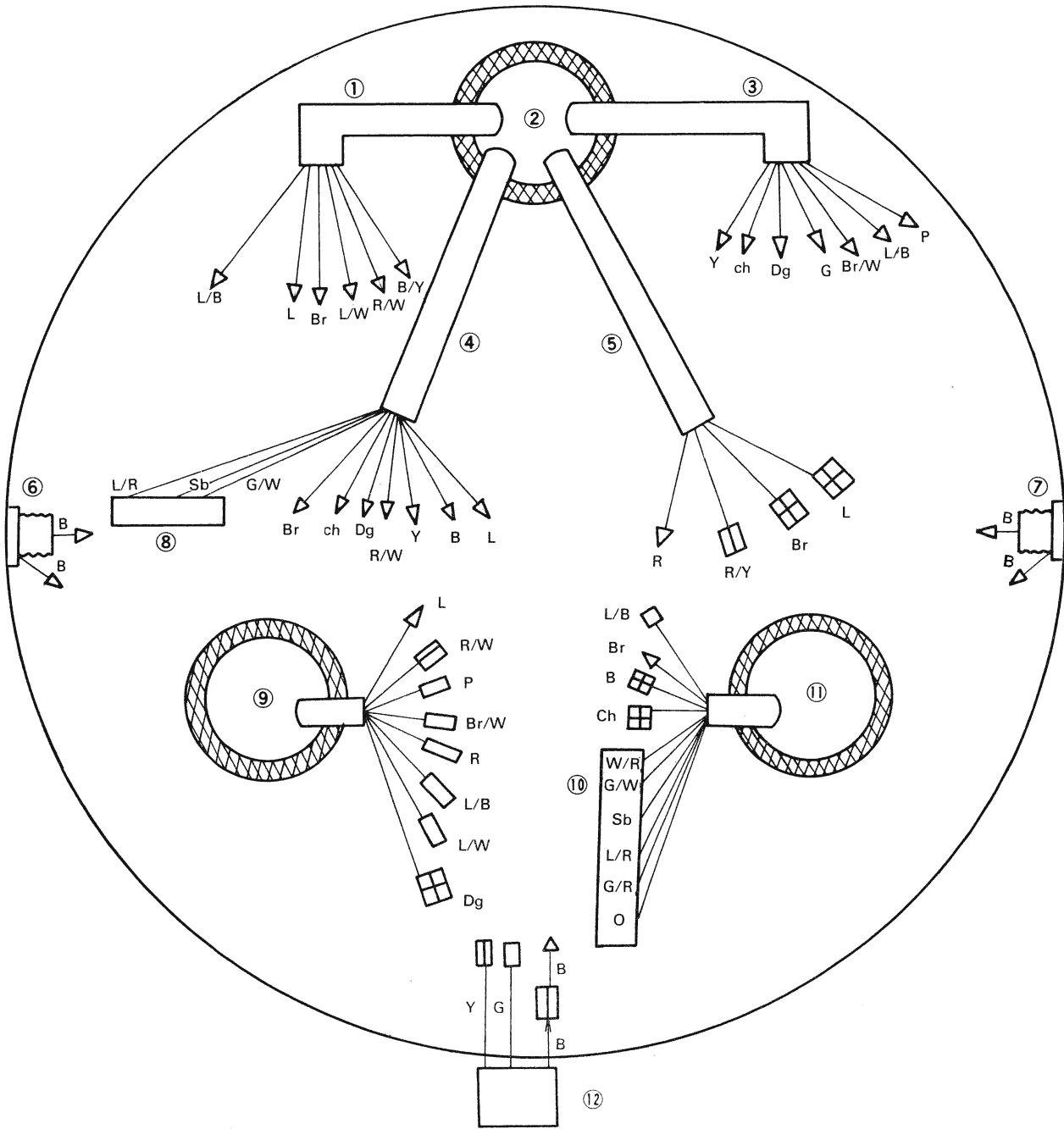

- | | |
|---|---|
| <p>1. From handle switch (R)
 2. Upper side (center)
 3. From handle switch (L)
 4. From meter panel
 5. From main switch
 6. Front flasher (R)</p> | <p>7. Front flasher (L)
 8. Multiple connector
 9. Lower side grommet (left)
 10. Multiple connector
 11. Lower side grommet (right)
 12. From headlamp lens assembly</p> |
|---|---|

Fig. 35

CONNECTION NOTES FOR TX650A ASSEMBLY

The lead wires of the identical color must be connected to each other with the exception of the following #1 to #3 connections.

- | | |
|---|--|
| #1. Left front flasher lamp lead wire B (Black) | — Left wire harness lead wire Ch (Dark brown) |
| #2. Right front flasher lamp lead wire B (Black) | — Right wire harness lead wire Dg (Dark green) |
| #3. Meter panel lead wires ⑧ (Multiple connector) | — Right wire harness ⑩ (Multiple connector) |

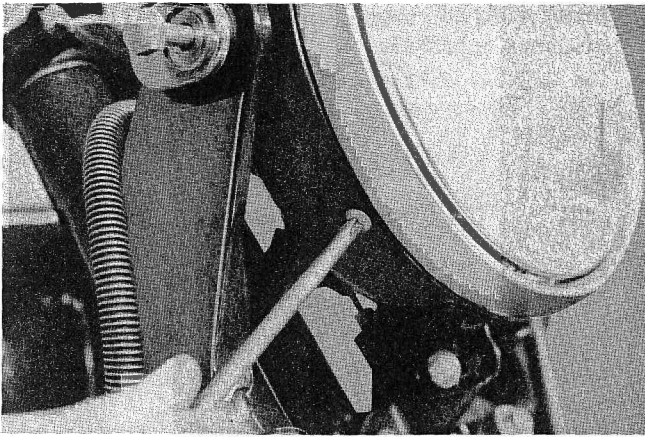

Fig. 36

29. Firmly fit the lens assembly in place. Make sure no wires are pinched. Then, secure the lens assembly with Phillips-head anchor screws. (Fig. 36)

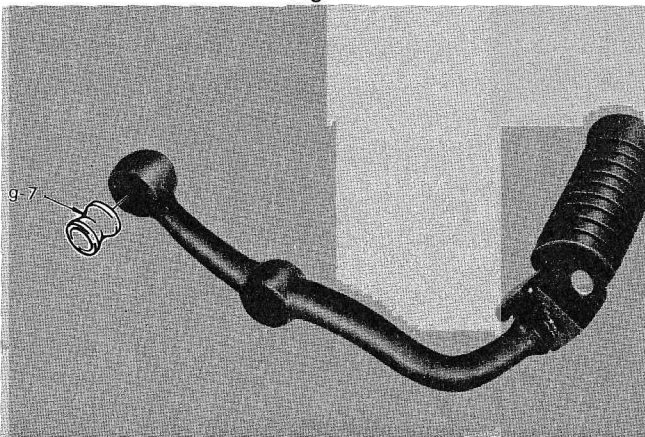

Fig. 37

30. Install the damper rubber (g-7) on the right foot rest. (Fig. 37)

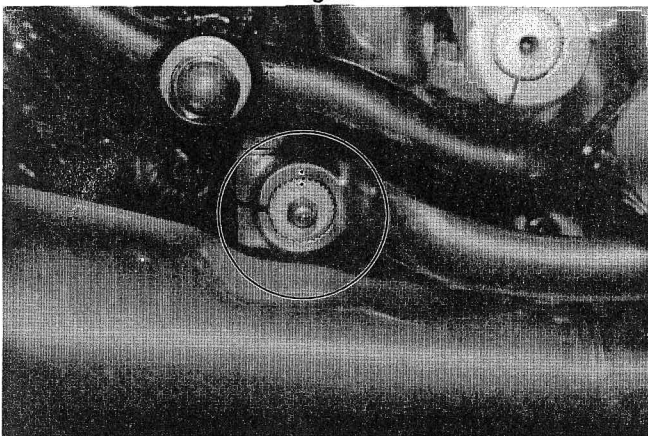

Fig. 38

31. Install the brake pedal (d) so that the punch mark on the brake pedal aligns with the punch mark on the brake shaft, and install the spring washer (g-15) and bolt (g-14). (Fig. 38)

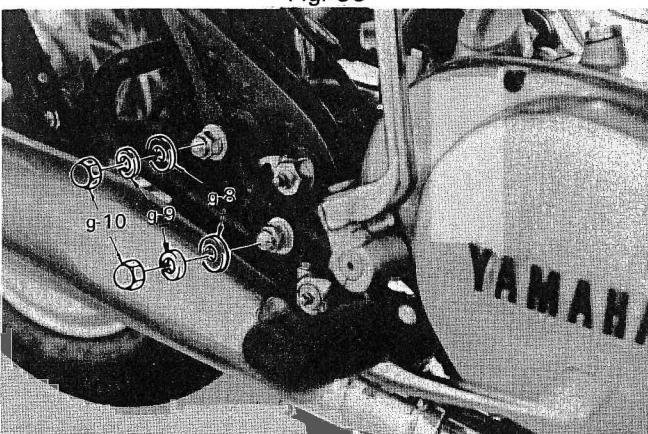

Fig. 39

32. Install the right foot rest assembly using two spring washers (g-9), two plain washers (g-8) and two crown nuts (g-10). (Fig. 39)

Tightening torque:

37.5 — 52.5 ft-lbs. (5.0 — 7.0 m-kgs.)

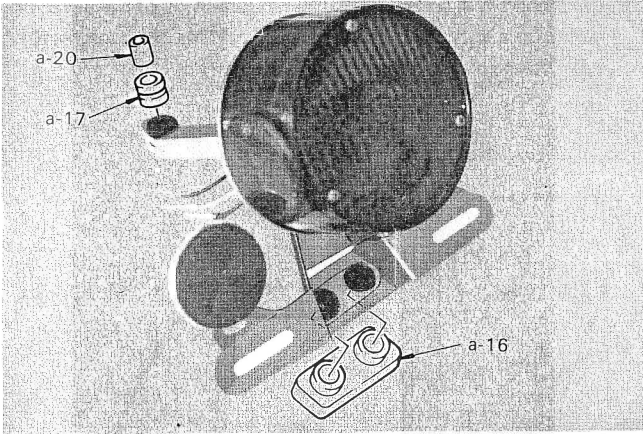

Fig. 40

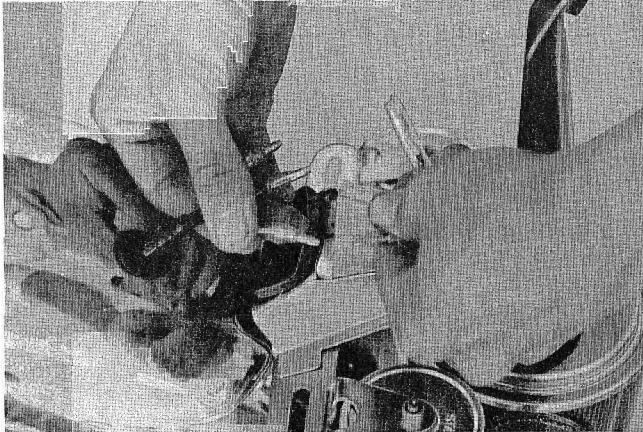

Fig. 41

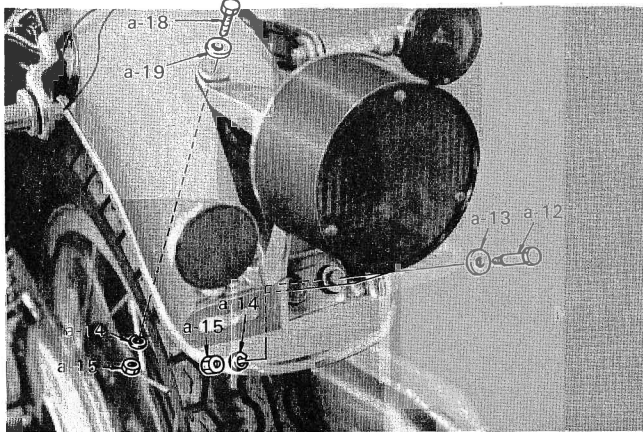

Fig. 42

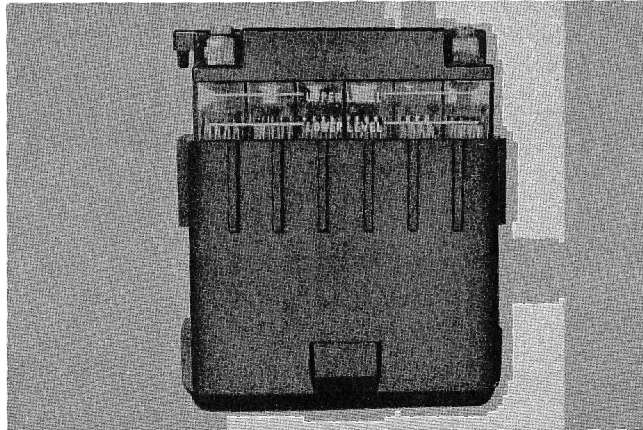

Fig. 43

33. Install the two rubber dampers (a-16, a-17), fender mounting collar (a-20) contained in the vinyl bag on the tail-stop lamp assembly (j) license bracket. (Fig. 40)

34. Connect the lead wires of the tail lamp assembly and secure them with the hook. (The lead wires of the identical color must be connected to each other.) (Fig. 41)

35. Secure the front part of the license bracket using the bolt (a-18), washer with cover (a-19), spring washer (a-14), and nut (a-15) contained in the vinyl bag (2) (Fig. 42)

36. Secure the rear part of the license bracket using two shoulder bolts (a-12), plain washers (a-13), spring washers (a-14) and nuts (a-15) contained in the vinyl bag (2). (Fig. 42)

- 37.
- a) Place the battery in the seat battery case.
 - b) Connect the breather pipe to the battery.
 - c) Remove the battery filler plugs.
 - d) Blow gently through the breather pipe to check for proper internal ventilation.
 - e) Fill each battery cell to the top level line with electrolyte. (Diluted sulphuric acid - specific gravity = 1.280) Take battery to well-ventilated area.
 - f) Place battery on trickle charger (maximum rate of charge = 1.5A.), and charge for 10 hours at 12V. or until specific gravity within each cell reaches 1.265.
 - g) Clean battery, refill cells, if necessary, and install filler plugs.

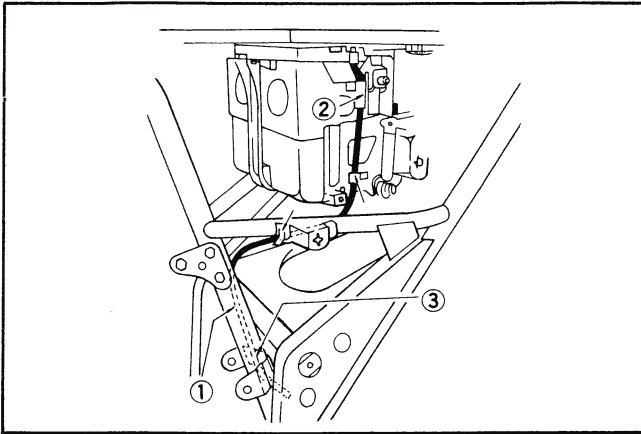

Fig. 44

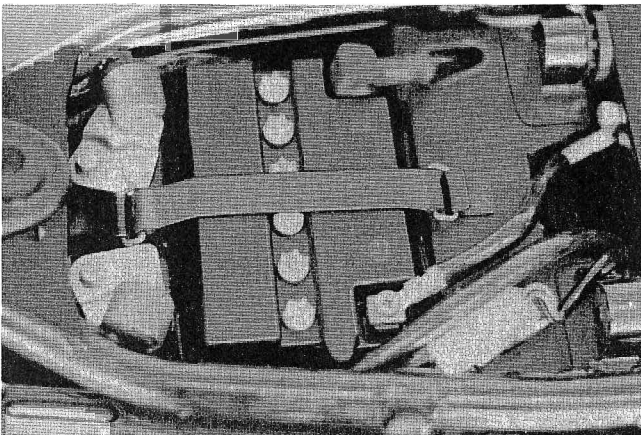

Fig. 45



Fig. 46

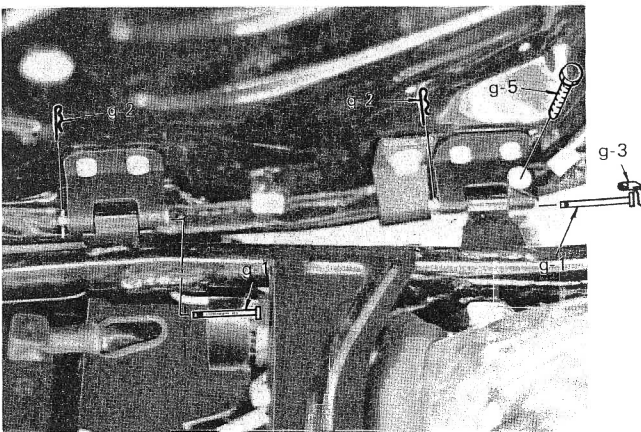

Fig. 47

38.

- a) Make sure the main switch is in the "OFF" position.
- b) Install the battery within the battery box. Connect the positive and negative lead wires to the battery. Make sure the positive lead is properly covered to prevent accidental grounding, during and after installation. Make sure the negative lead wire is properly grounded.
- c) Route the breather pipe as illustrated. (Fig. 44)

- 1. Right side
- 2. Pass through clamp 1. 2. 3.
- 3. Pass through clear space between bracket and engine

- d) Secure the battery with the band. (Fig. 45)

39. Remove the left side cover and insert the tool assembly (b) in the tool box. Install the left side cover. (Fig. 46)

40. Secure the seat using the clips (g-2), clevis pins (g-1), spring washer (g-4) and stopper (g-3), as shown in the photo. (Fig. 47)

Starting at the front of the unit, inspect the following fittings, mounts, and fasteners for correct installation and fastener torque:

1. Front wheel spoke tightness.
2. Front wheel rim deflection and run-out.
3. Front wheel tire pressure.
4. Front wheel axle nut and cotter pin.
5. Front wheel axle holder securing nuts.
6. Disc brake caliper assembly securing bolts.
7. Front fork securing bolts.
8. Steering head lock nuts.
9. Handlebar holder securing bolts.
10. Handle lever, disc brake, and throttle assembly mounts.
11. Engine mounting bolts.
12. Cylinder head securing nuts.
13. Carburetor mounting flange screws.
14. Foot rest mounts.
15. Change pedal securing bolt.
16. Brake pedal mount and actuating mechanism.
17. Rear fender and taillight mounts.
18. Rear shock (cushion) mounting nuts.
19. Rear swing arm pivot securing nuts.
20. Rear axle lock nut and cotter pin.
21. Chain adjust bolts and lock nuts.
22. Rear wheel spoke tightness.
23. Rear wheel rim deflection and run-out.
24. Rear wheel tire pressure.

THIS CONCLUDES THE ASSEMBLY PORTION. HOWEVER, THE UNIT MUST STILL BE "SET-UP" FOR DELIVERY TO THE CUSTOMER.

For specifications regarding ignition timing, carburetor adjustment, tire pressures, engine oil type and quantity, etc., refer to appropriate sections of TX650 service manual.

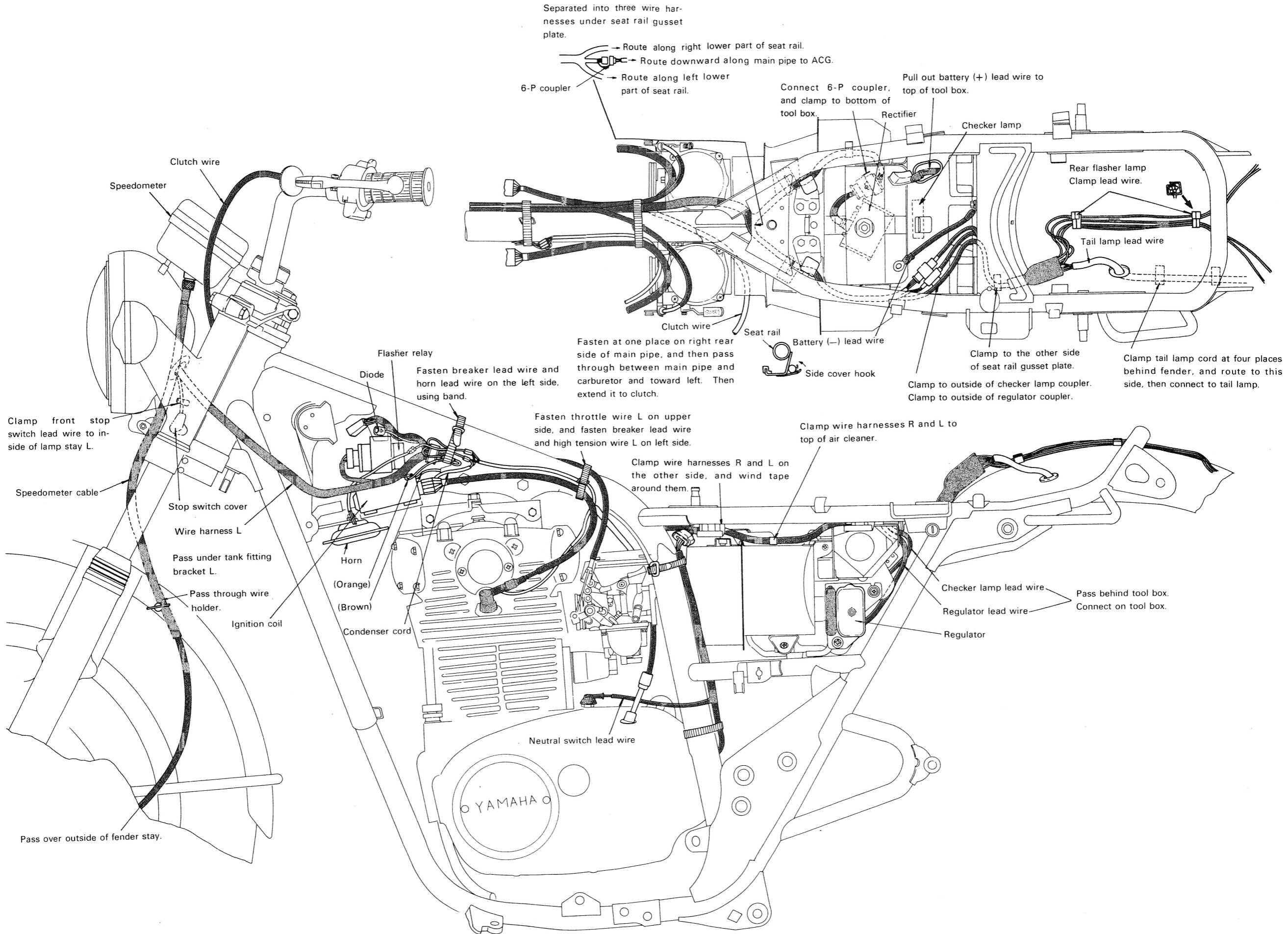

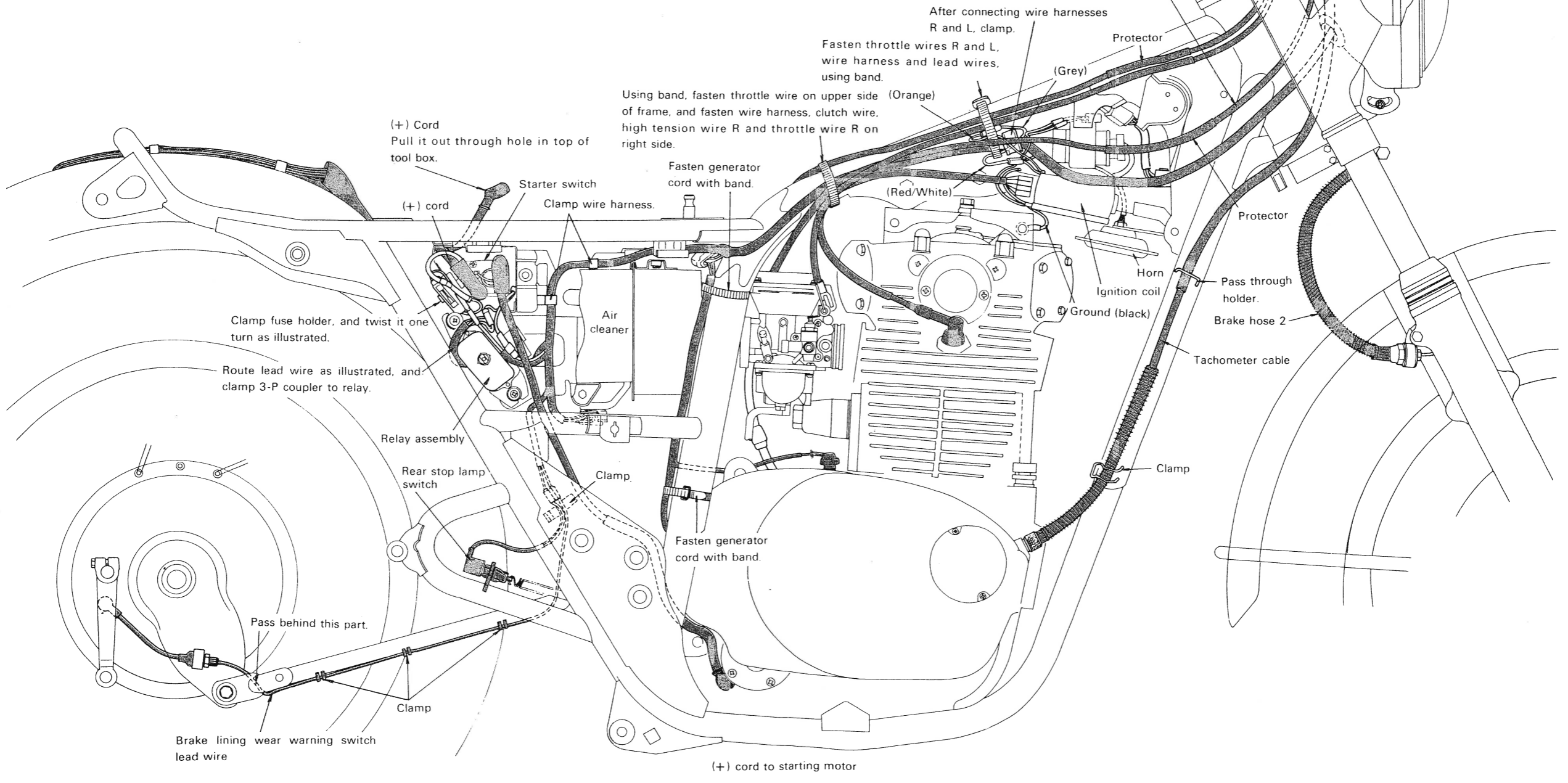
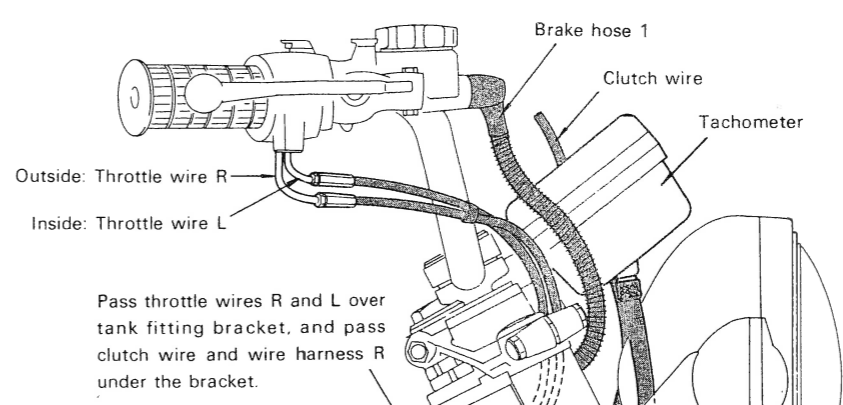
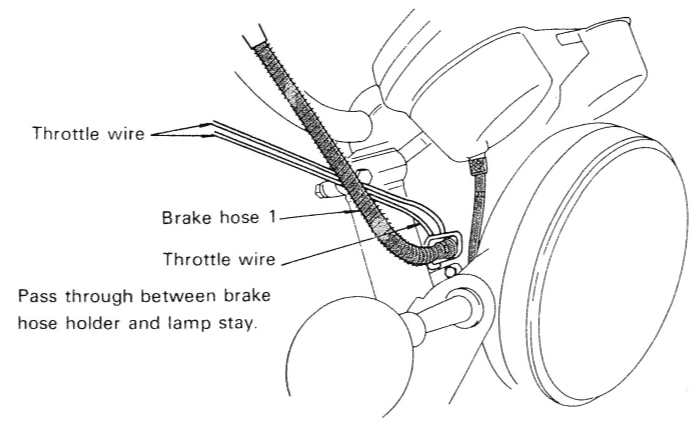
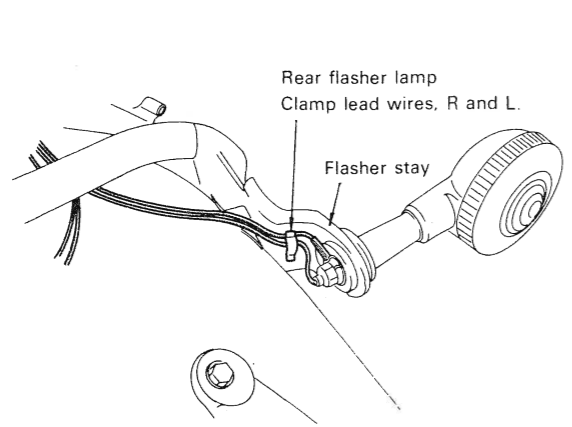

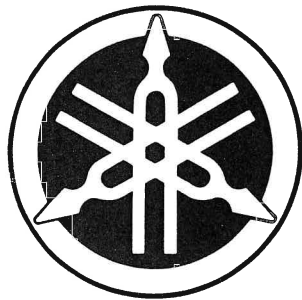

YAMAHA MOTOR CO., LTD.

SINCE 1887

IWATA, JAPAN

LIT-11664-47-00

Printed in Japan
74 · 1 - 2.8 x 1 ©